

∞ Infinity Wash XL

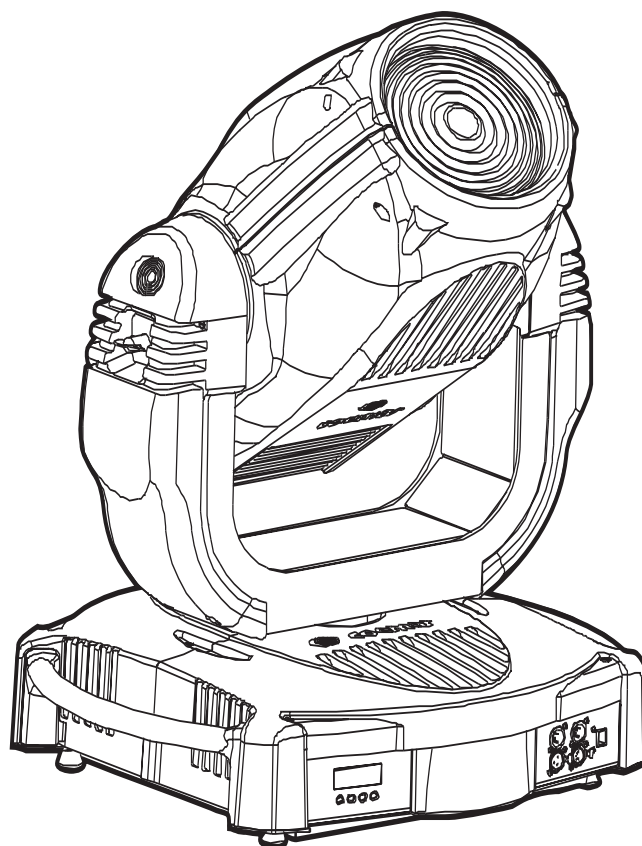

**instructions manual
manuale di istruzioni**

**Version 1.0
DIS91/1**

coemar
LIGHT EMOTION

Infinity Wash XL

numero di serie/serial number

data di acquisto/date of purchase

fornitore/retailer

indirizzo/address

cap/città/suburb

provincia/capital city

stato/state

tel./fax/

Prendete nota, nello spazio apposito, dei dati relativi al modello e al rivenditore del vostro **Infinity Wash XL**: ci permetteranno di assistervi con la massima rapidità e precisione.

*Please note in the space provided above the relative service information of the model and the retailer from whom you purchased your **Infinity Wash XL**: This information will assist us in answering any technical enquiries with the utmost speed and accuracy.*

ATTENZIONE: *la sicurezza dell'apparecchio è garantita solo con l'uso appropriato delle presenti istruzioni, pertanto è necessario conservarle.*

WARNING: *the security of the fixture is granted only if these instructions are strictly followed; therefore it is absolutely necessary to keep this manual.*

Index

1. Packaging and transportation	Pag. 6
1.1. Packaging	" 6
1.2. Transportation	" 6
2. General information	Pag. 6
2.1. Important safety information	" 6
2.2. Warranty conditions	" 7
2.3. CE norms	" 7
3. Product specifications	Pag. 7
3.1. Technical characteristics	" 7
3.2. Dimensions	" 7
3.3. Projector components	" 7
4. Installation	Pag. 8
4.1. Mechanical installation	" 8
4.2. Safety connections	" 8
5. Powering up	Pag. 9
5.1. Operating voltage and frequency	" 9
5.2. Altering the operating voltage and frequency	" 9
5.3. Mains connection	" 10
6. DMX signal connection	Pag. 11
7. Turning on the projector	Pag. 12
7.1. DMX addressing	" 12
7.2. DMX functions	" 13
8. Display panel functions	Pag. 15
8.1. Quick guide to menu navigation	" 15
8.2. Rapid scrolling	" 15
8.3. Main functions	" 16
8.4. Measures	" 18
8.5. Display setup	" 19
8.6. Demo mode	" 19
8.7. Special mode and motors electronic alignment	" 20
9. Lamp installation and alignment	Pag. 21
9.1. Lamp installation	" 21
9.2. Aligning the lamp in the optical path	" 22
10. Removing the colour changer assembly	Pag. 21
11. Maintenance	Pag. 23
11.1. Periodic cleaning	" 24
11.2. Periodic maintenance	" 24
11.3. Fuse replacement	" 24
11.4. Electronic motor alignment	" 24
12. Spare parts	Pag. 24
13. Error messages	Pag. 25
14. Frequently asked questions	Pag. 26

English

Congratulations on having purchased a **Coemar** product. You have assured yourself of a fixture of the highest quality, both in componentry and in the technology used. We renew our invitation to you to complete the service information on the previous page, to expedite any request for service information or spares (in case of problems encountered either during, or subsequent to, installation). This information will assist in providing prompt and accurate advice from your **Coemar** service centre. Following the instructions and procedures outlined in this manual will ensure the maximum efficiency of this product for years to come.

1. Packaging and transportation

1.1. Packaging

Open the packaging and ensure that no part of the equipment has suffered damage in transit. In case of damage to the equipment, contact your carrier immediately by telephone or fax, following this with formal notification in writing.

Packing list

Ensure the packaging contains:

- 1 **Infinity Wash XL**
- 1 **instruction manual**
- 2 **cam-lock support brackets**

1.2. Transportation

The **Infinity Wash XL** should be transported in its original packaging or in an appropriate flight case.

2. General information

2.1. Important safety information

Fire prevention:

1. **Infinity Wash XL** utilises a **Philips MSR GOLD 1200 SA/SE FastFit**; the use of any alternative lamp is not recommended and will null and void the fixture's warranty.
2. Never locate the fixture on any flammable surface.
3. Minimum distance from flammable materials: 0,5 m.
4. Minimum distance from the closest illuminable surface: 2 m.
5. Replace any blown or damaged fuses only with those of identical values. Refer to the schematic diagram if there is any doubt.
6. Connect the projector to mains power via a thermal magnetic circuit breaker.

Preventing electric shock:

1. High voltage is present in the internals of the unit. Isolate the projector from mains supply prior to performing any function which involves touching the internals of the unit, including lamp replacement.
2. For mains connection, adhere strictly to the guidelines outlined in this manual.
3. The level of technology inherent in the **Infinity Wash XL** requires the use of specialised personnel for all service applications; refer all work to your authorised **Coemar** service centre.
4. A good earth connection is essential for proper functioning of the projector.
5. Mains cables should not come into contact with other cables. Never operate the unit without proper earth connection.
6. Do not operate the projector with wet hands or in an area where water present.
7. The fixture should never be located in an exposed position, or in areas of extreme humidity. A steady supply of circulating air is essential.

Protection against ultraviolet radiation:

1. Never turn on the lamp if any of the lenses, filters, or the carbon fibre housing is damaged; their respective functions will only operate efficiently if they are in perfect working order.
2. Never look directly into the lamp when it is operating.

Safety:

1. The projector should always be installed with bolts, clamps, and other fixings which are suitably rated to support the weight of the unit.
2. Always use a secondary safety chain of a suitable rating to sustain the weight of the unit in case of the failure of the primary fixing point.
3. The external surface of the unit, at various points, may exceed 150°C. Never handle the unit until at least 10 minutes have elapsed since the lamp was turned off.
4. Always replace the lamp if any physical damage is evident.
5. Never install the fixture in an enclosed area lacking sufficient air flow; the ambient temperature should not exceed 35°C.
6. Wait at least 10 minutes after the unit has been turned off prior to attempting to replace the lamp.
7. The projector contains electronic and electrical components which should under no circumstances be exposed to contact with water, oil or any other liquid. Failure to do so will compromise the proper functioning of the projector.

Articulated movement

The projector has a pan range of 540° in its base and a tilt range 262° in its yoke; do not obstruct the projector whilst it is undertaking articulated movement.

Forced ventilation

You will note several air vents on the body of the projector. To avoid any problems associated with overheating, never obstruct any of these vents as this may seriously compromise the proper operation of the unit.

Protection rating against penetration by external agents:

1. The fixture is classified ordinary apparatus ; its protection grade against penetration by external agents, solid or liquid, is **IP 20**.

2.2. Warranty conditions

1. The fixture is guaranteed for a period of 12 months from the date of purchase against manufacturing or materials defects.
2. The warranty does not extend to damage caused by inappropriate usage or use by inexperienced operators.
3. The warranty is immediately void if the projector has been operated or dismantled by unauthorised personnel.
4. The warranty does not extend to fixture replacement.
5. The serial number of the projector is required for any advice or service from your authorised **Coemar** service centre.

2.3. CE norms

The projector meets or exceeds all applicable CE requirements.

3. Product specifications

3.1. Technical characteristics

Power:	200/208/230/240 Vac 50/60Hz
Nominal current:	8A
Maximum current:	10A
Power factor:	cos ϕ = 0,9
Lamp wattage:	1200W MH
Maximum ambient temperature:	35°C / 95° F
Weight:	45.5 Kg / 100.1 Lbs
IP rating:	IP20

3.2. Dimensions

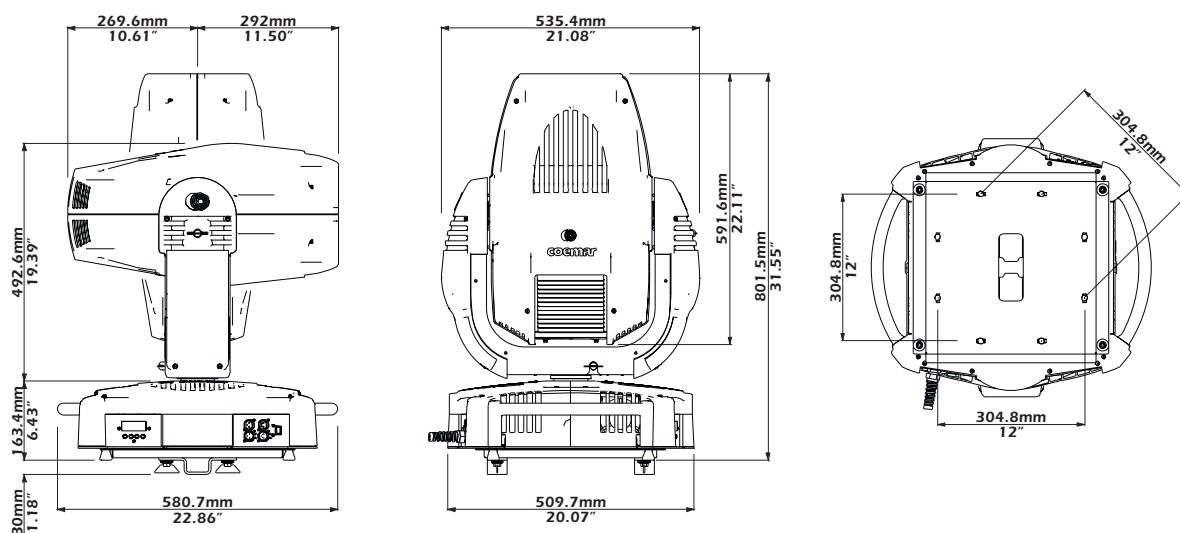

3.3. Components

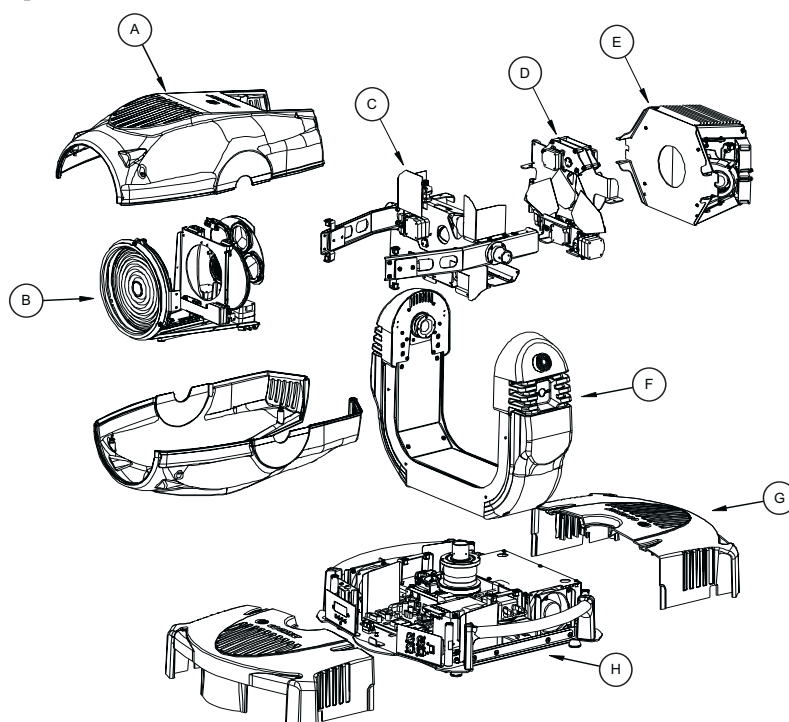

Component description

- A.** Body housing
- B.** Zoom effect group
- C.** Color wheel group
- D.** Colors changer group
- E.** Reflector group
- F.** Yoke
- G.** Base housing
- H.** Base

4. Installation

4.1. Mechanical installation

Infinity Wash XL may be either floor or ceiling mounted. For floor mounting, the unit is provided with four rubber mounting feet. For ceiling mounted installations, **Coemar** includes two cam-lock (A) support brackets.

The two cam-lock brackets may be mounted in 3 different positions (B, C and D) on the base of the **Infinity Wash XL**. The cam-lock brackets are affixed via a 1/4 nut. Please ensure that they are correctly seated and firmly tightened into position.

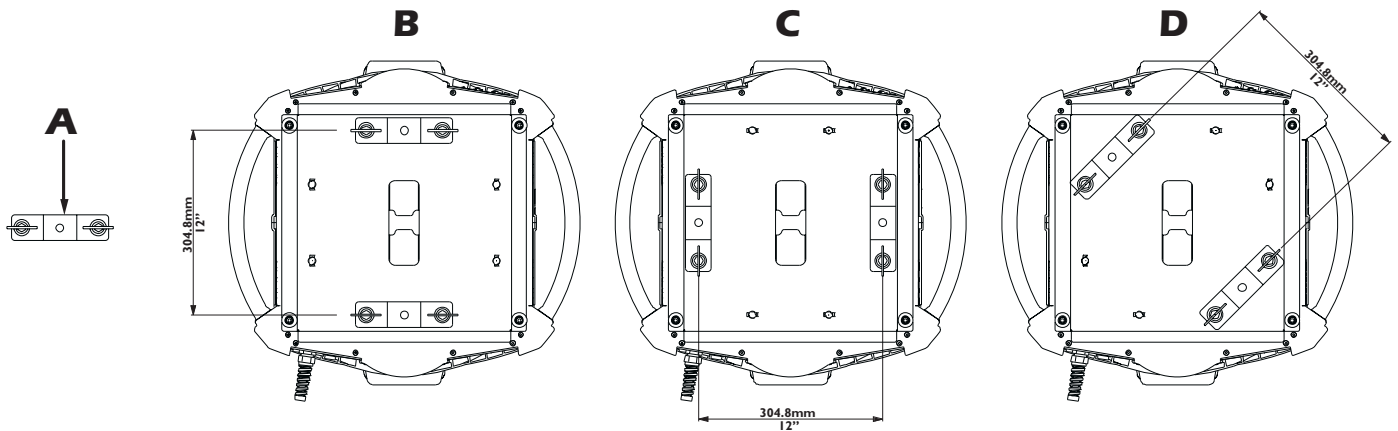

For ceiling mounted installations we suggest the use of appropriate clamps or fixings to attach the fixture to the mounting surface. Clamps may be attached to the central hole provided in the cam-lock brackets, as shown in the following diagram.

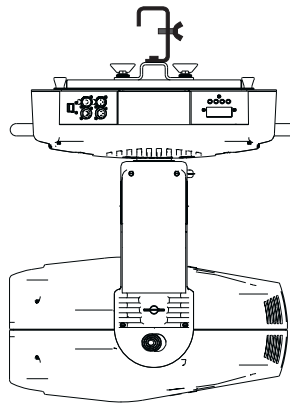

ATTENTION!!

Ensure that the structure from which the unit is hung is of sufficient rating to hold the weight of the unit, as are any clamps, nuts and bolts used to hang the unit.

The structure from which the unit is hung should be of sufficient rating to hold the weight of the unit, as should any clamps used to hang the unit. The structure should also be sufficiently rigid so as not to move or shake whilst the projector moves during its operation. Do not install the projector in locations where it is readily accessible by authorised or untrained personnel.

4.2. Safety connections

If the **Infinity Wash XL** is affixed to a structure the use of a safety chain designed to meet relevant safety standards is recommended. You may attach the safety chain to the holes "E" located on the base of the fixture and to the structure itself.

If using an after-market safety chain not manufactured by **Coemar**, ensure that it is of sufficient rating to hold the weight of the unit.

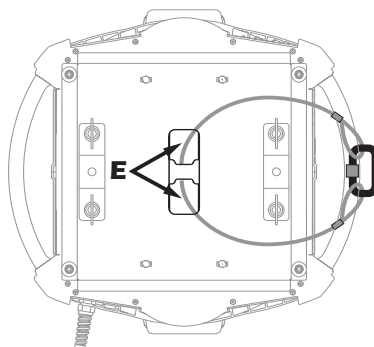

5. Powering up

5.1. Operating voltage and frequency

The projector may operate at voltages of 200, 208, 230 or 240VAC at a frequency of 50 or 60Hz. **Coemar** presets (barring specific requests) a voltage of 230v at a frequency of 50Hz.. The preset voltage is indicated on the base of the projector.

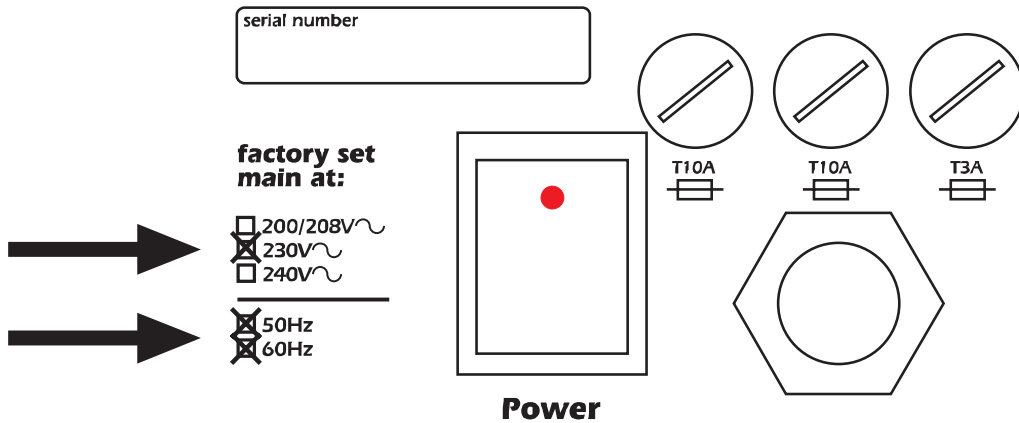

Infinity Wash XL will automatically adjust its operation to suit a frequency of 50Hz or 60Hz.

5.2. Altering the operating voltage (Reserved for technical personnel only)

If the factory preset operating voltage do not correspond to those in use in your country of operation, you may alter the settings as described in the following paragraphs.

ATTENTION!!

Incorrect selection of operating voltage will seriously compromise the functioning of the projector and will immediately void the warranty.

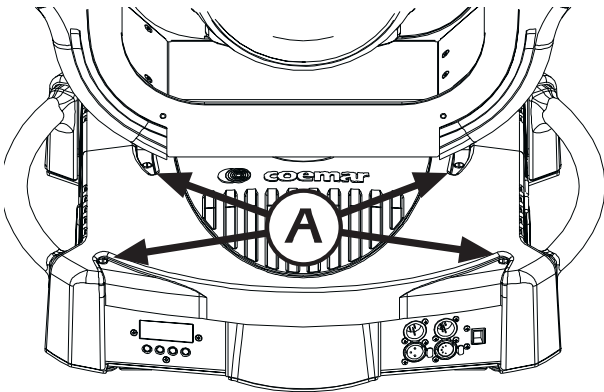

1. Loosen the screws "A" on the cover of the base of the unit, as shown in the diagram below, using an appropriate screwdriver, thereby removing the cover completely and allowing access to the internal components of the base of the **Infinity Wash XL**.

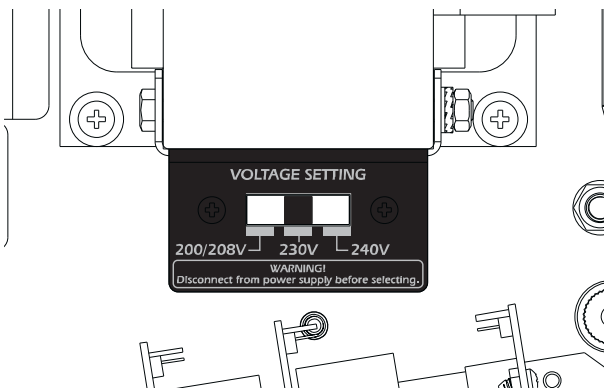

2. Locate the main selector in the base of the unit.
3. Select a voltage from amongst 200, 208, 230 or 240V by moving the selector to the correct voltage.
4. When you have made changes, note these on the outside of the **Infinity Wash XL**.
5. Replace and fasten all the housings as per their original positions.

English

5.3. Mains connection

Mains cable characteristics

The mains cable provided is thermally resistant, complying to the most recent international standards. It meets or exceeds VDE and IEC norms, IEC 331, IEC 332 3C, CEI 20 35.

NB: In case of cable replacement, similar cable with comparable thermal resistant qualities must be used exclusively (cable 3x1.5 \varnothing external 10 mm, rated 300/500V, tested to 2KV, operating temperature $-40^{\circ} +180^{\circ}$, **Coemar** cod. CV5309).

Connecting to mains power

For connection purposes, ensure your plug is of a suitable rating to sustain the maximum current:

- 200/208/230/240Vac 4.5 amps constant current in normal operation

Locate the mains cable which exits the base of the unit and connect as shown below:

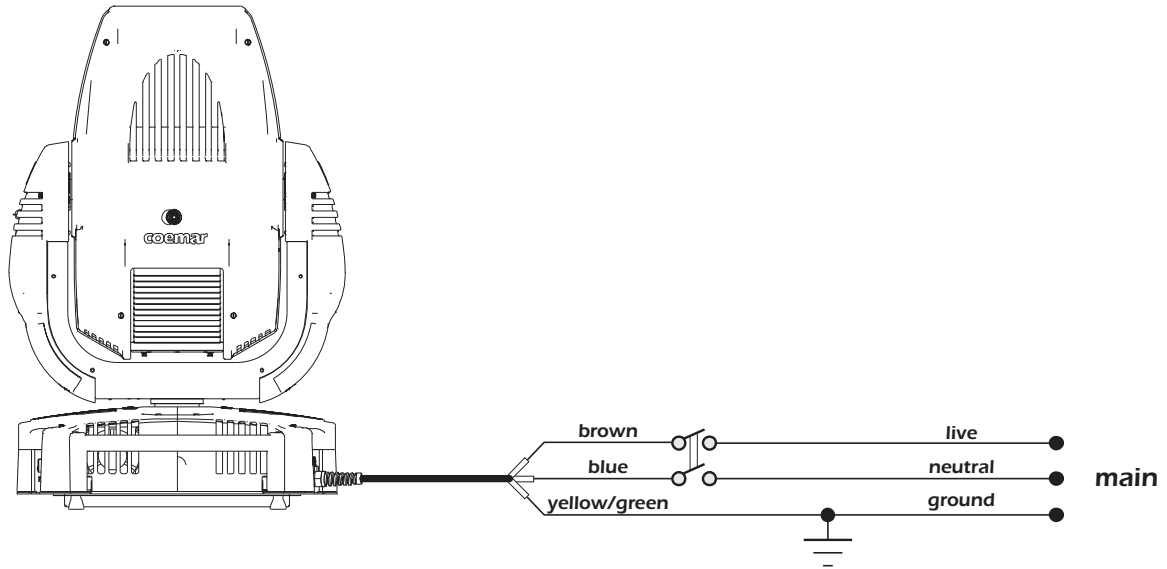

ATTENTION!!

- The use of a thermal magnetic circuit breaker is recommended for each projector. Strict adherence to all regulatory norms is highly recommended.
- Infinity Wash XL should never be supplied mains power via a Dimmer; this is potentially dangerous.
- Prior to powering up the projector, ensure that the model in your possession correctly matches the mains supply available to you.
- A good earth connection is essential for the correct operation of the Infinity Wash XL. Never connect the projector to main power if the green/yellow earth cable is not correctly connected
- All cable and plug connections should be carried out by fully qualified and licenced personnel only.

6. DMX signal connection

Control signal is digital and is transmitted via two pair screened $\varnothing 0.5\text{mm}$ cable as per international standards for the transmission of DMX512 data. Connection is serial, utilising XLR3 and XLR5, male and female sockets located on the base of the **Infinity Wash XL**, labelled **DMX 512 IN** and **OUT** (see diagram).

Plug/socket connections for XLR3 and XLR5 connectors:

Pin connections conform to the international standard as per the following table:

- pin 1 = GND
- pin 2 = data -
- pin 3 = data +

If using a controller which output signal via an XLR 5 (5 pin) socket, do not use pins 4 and 5, leave them unconnected.

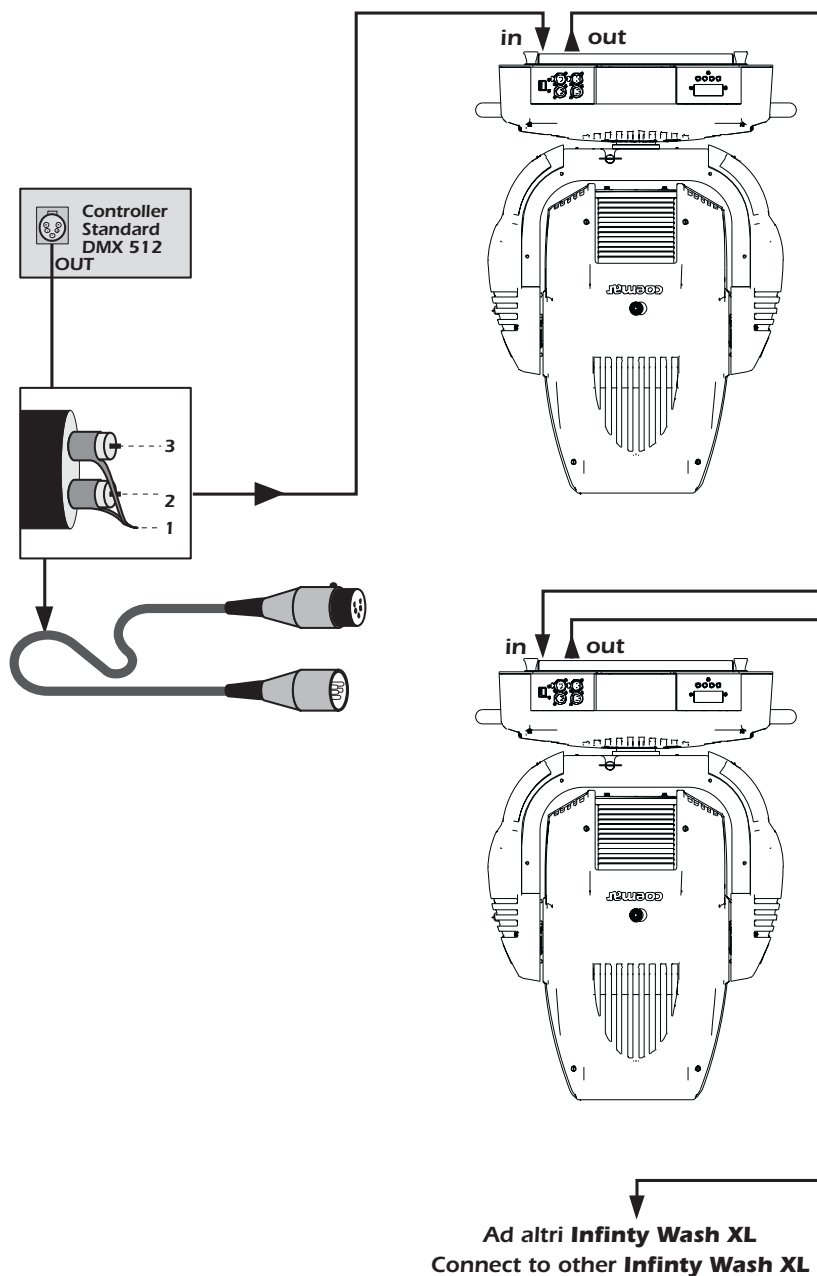

ATTENTION!!

Ensure that all data conductors are isolated from one another and the metal housing of the connector. Pin number 1 should never be connected to the device's power supply.

7. Turning on the projector

After having followed the preceding steps, turn on the projector via the main **Power** switch.

The display will show in sequence the software version installed on the onboard microprocessors . For example, upon turning on power, the **Infinity Wash XL** may show:



Software version currently installed on the electronic boards of the fixture

The projector will perform a reset function on all the internal and external motors. This will last only few seconds, after which it will be subject to the external signal from the controller. The display will remain fixed indicating the correct **DMX 512** signal reception.

If the display is flashing, there is no DMX signal being received. Check your cabling and your controller.



During the reset the display will blink for few seconds...



...then the DMX address of the fixture will appear.

7.1. DMX addressing

Each projector utilises **22** channels of **DMX 512** for complete control (for further information, see section **7.2. DMX functions**).

DMX addresses

To ensure that each projector accesses the correct signal, it is necessary to correctly address each fixture. This procedure must be carried out on every projector being used. When powered up initially, each projector will show **A001** which indicates **DMX address 001**; a projector thus addressed will respond to commands on channel **1** to **22** from your **DMX controller**. A second unit should be addressed as **A023**, a third as **A045** and so on until the final projector has been addressed.

Altering DMX addresses

1. Press the **+** or **-** buttons until the display shows the required **DMX** address. The characters in the display will flash to indicate that the selection is not yet stored in memory.
2. Press the **enter** button to confirm your selection. The display panel will cease to flash and the projector will now respond to the new **DMX 512** address.

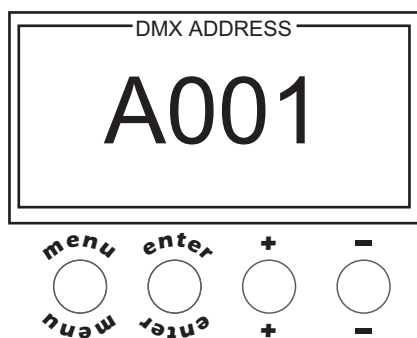

Important Note: holding down the **+** or **-** buttons will cause the display to alter at an increased speed, allowing a faster selection to be made.

ATTENTION!!

If you alter the DMX with no DMX controller connected, the characters in the display panel will continue to flash even after you have pressed the ENTER button.

7.2. DMX functions

dmx channel	function	type of control	effect	decimal	percentage
1	X axis, base movement (pan) coarse	proportional	proportional coarse control of the base motor movement	0 - 255	0% - 100%
2	X axis, base movement (pan) fine	proportional	proportional fine control of the base motor movement	0 - 255	0% - 100%
3	Y axis, yoke movement (tilt) coarse	proportional	proportional coarse control of the yoke motor movement	0 - 255	0% - 100%
4	Y axis, yoke movement (tilt) fine	proportional	proportional fine control of the yoke motor movement	0 - 255	0% - 100%
5	movement speed	step	standard (fast)	0 - 9	0% - 4%
		step	ultra fast movement (best for programming positions)	10 - 25	4% - 10%
		proportional	vector mode (from fast to slow)	26 - 127	10% - 50%
		proportional	tracking mode (from fast to slow)	128 - 247	50% - 97%
		step	tracking mode (slow)	248 - 255	97% - 100%
6	dimmer	proportional	gradual adjustment of luminous intensity from 0 to 100%	0 - 255	0% - 100%
7	shutter, strobe and zap effect	step	shutter closed (zap off)	0 - 9	0% - 4%
		proportional	strobe effect with variable speed from slow to fast	10 - 66	4% - 26%
		step	shutter open (zap off)	67 - 68	26% - 27%
		proportional	sequenced pulse effect, slow closing, fast opening (with variable speed from slow to fast)	69 - 125	27% - 49%
		step	shutter open (zap off)	126 - 127	49% - 50%
		proportional	sequenced pulse effect, fast closing, slow opening (with variable speed from fast to slow)	128 - 184	50% - 72%
		step	shutter open (zap off)	185 - 187	73% - 73%
		proportional	random strobe effect, non-synchronised, variable speed from slow to fast	188 - 244	74% - 96%
step	shutter open (zap off)	245 - 255	96% - 100%		
8	zoom effect	proportional	proportional control of zoom effect wheel from narrow to wide beam (from 6° to 13°)	0 - 255	0% - 100%
9	zoom	proportional	proportional control of zoom from narrow to wide beam (from 6° to 80°)	0 - 255	0% - 100%
10	zoom shake	step	no effect	0 - 9	0% - 4%
		proportional	zoom shake effect with variable speed from slow to fast	10 - 71	4% - 28%
		proportional	zoom shake sequenced pulse effect, slow closing, fast opening (with variable speed from slow to fast)	72 - 133	28% - 52%
		proportional	zoom shake sequenced pulse effect, fast closing, slow opening (with variable speed from fast to slow)	134 - 195	53% - 76%
		proportional	zoom shake random strobe effect, non-synchronised, variable speed from slow to fast	196 - 255	77% - 100%
11	selecting effects wheel + shake movement	step	no effect	0 - 9	0% - 4%
			effect 1	10 - 39	4% - 15%
			effect 2	40 - 69	16% - 27%
			effect 3	70 - 99	27% - 39%
			effect 4	100 - 128	39% - 50%
		proportional	shake effect 4 (variable adjustment of oscillation angle from minimum to maximum)	129 - 160	51% - 63%
			shake effect 3 (variable adjustment of oscillation angle from minimum to maximum)	161 - 192	63% - 75%
			shake effect 2 (variable adjustment of oscillation angle from minimum to maximum)	193 - 224	76% - 88%
shake effect 1 (variable adjustment of oscillation angle from minimum to maximum)	225 - 255	88% - 100%			
12	indexing effect rotation through 360°	step	no effect	0 - 9	0% - 4%
		proportional	proportional indexing of the effect through 360°	10 - 128	4% - 50%
		proportional	continuous rotation of the effect in a counter-clockwise direction with proportional control over decreasing speed	129 - 188	51% - 74%
		step	stop effect rotation	189 - 193	74% - 76%
		proportional	continuous rotation of the effect in a clockwise direction with proportional control over increasing speed	194 - 255	76% - 100%

dmx channel	function	type of control	effect	decimal	percentage
13	selecting colors from the color wheel	step	no colour, white beam	0 - 5	0% - 2%
			color 1	6 - 14	2% - 5%
			color 2	15 - 22	6% - 9%
			color 3	23 - 30	9% - 12%
			color 4	31 - 38	12% - 15%
		color 5	39 - 45	15% - 18%	
		proportional	from color 5 to colour 1, proportional positioning	46 - 127	18% - 50%
			rainbow effect from fast to slow in an anticlockwise direction	128 - 190	50% - 75%
rainbow effect from slow to fast in a clockwise direction	191 - 255		75% - 100%		
14	cyan	proportional	proportional control of the percentage of cyan color in the light beam from 0 to 100%	0 - 255	0% - 100%
15	cyan color saturation	proportional	saturation adjustment of cyan color tonality; from bright to dark	0 - 255	0% - 100%
16	magenta	proportional	proportional control of the percentage of magenta color in the light beam from 0 to 100%	0 - 255	0% - 100%
17	magenta color saturation	proportional	saturation adjustment of magenta color tonality; from bright to dark	0 - 255	0% - 100%
18	yellow	proportional	proportional control of the percentage of yellow color in the light beam from 0 to 100%	0 - 255	0% - 100%
19	CTO	proportional	proportional control of the percentage of CTO in the light beam from 6300°K to 3200°K	0 - 255	0% - 100%
20	zap effect (effect varies depending upon channel 7 strobe)	step	no effect	0 - 10	0% - 4%
			zap effect synchronised with the strobe effect, speed and mode selected by strobe channel 7	11 - 30	4% - 12%
			zap effect, flicker and speed adjustable, speed and mode selected by strobe channel 7	31 - 249	12% - 98%
			black-out of the light beam during PAN/TILT movement, colors wheel and effects wheel	250 - 255	98% - 100%
21	lamp power control in conjunction with channel 22	proportional	lamp power adjustment from minimum to maximum (800W - 1400W) when channel 22 is between 171 - 195 dmx	0 - 255	0% - 100%
22	lamp on/off and motors reset	step	park, no function	0 - 9	0% - 4%
			lamp off	10 - 29	4% - 11%
			pan and tilt reset (once only)	30 - 65	12% - 25%
			all motor reset except dimmer, pan and tilt (once only)	66 - 100	26% - 39%
			all motor reset except dimmer (once only)	101 - 135	40% - 53%
			reset of all the motors (once only)	136 - 170	53% - 67%
			lamp on, enabled power adjustment from 800W to 1400W	171 - 195	67% - 76%
			lamp on, maximum power	171 - 255	67% - 100%

Note 1: the display panel may be used to disable the switching off of the lamp via DMX

Note 2: turning off the lamp and all reset functions are delayed by 6 seconds to prevent accidental activation

Note 3: the lamp on/off function can only be effected if an opposite level is set

8. Display panel functions

The display panel of the **Infinity Wash XL** shows all the functions available; it is possible to change some of those parameters and to add some functions.

Changing the preset settings made by **Coemar** can vary the functions of the device so that it may not respond to a **DMX 512** controller being used to control it. Carefully follow the instructions before applying any variations or selections.

8.1. Quick guide to menu navigation

In order to access to the functions, just push the menu button: a screen divided into four sections will appear; the sections will highlight cyclically one by one every time a + or - button is pushed. To select the desired function, push enter. The following diagram fastly shows the content of every section..

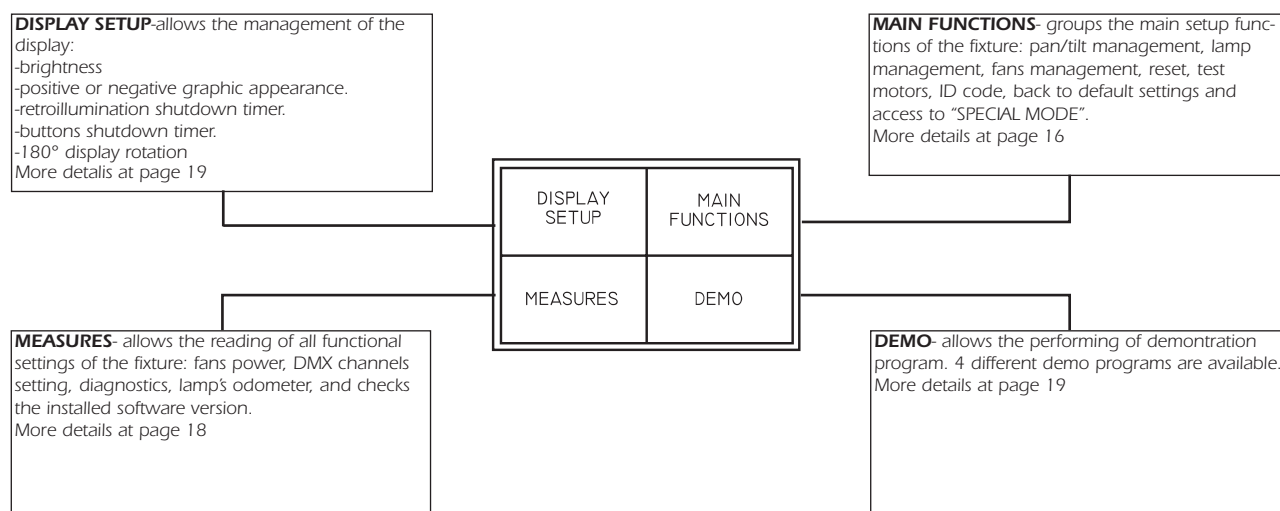

8.2. Rapid scrolling

Via the **Infinity Wash XL** display it is possible to rapidly scroll through the various numbers displayed in the menu in the following manner:

1. Pressing the **+** or **-** buttons will cause the number to scroll more quickly.
2. Pressing and holding the **+** button and then the **-** button will cause the numbers to jump to the highest value.
3. Pressing and holding the **-** button and then the **+** button will cause the numbers to jump to the lowest value.

8.3. Main functions

This section gives the opportunity to change and customize some functional settings of the fixture.

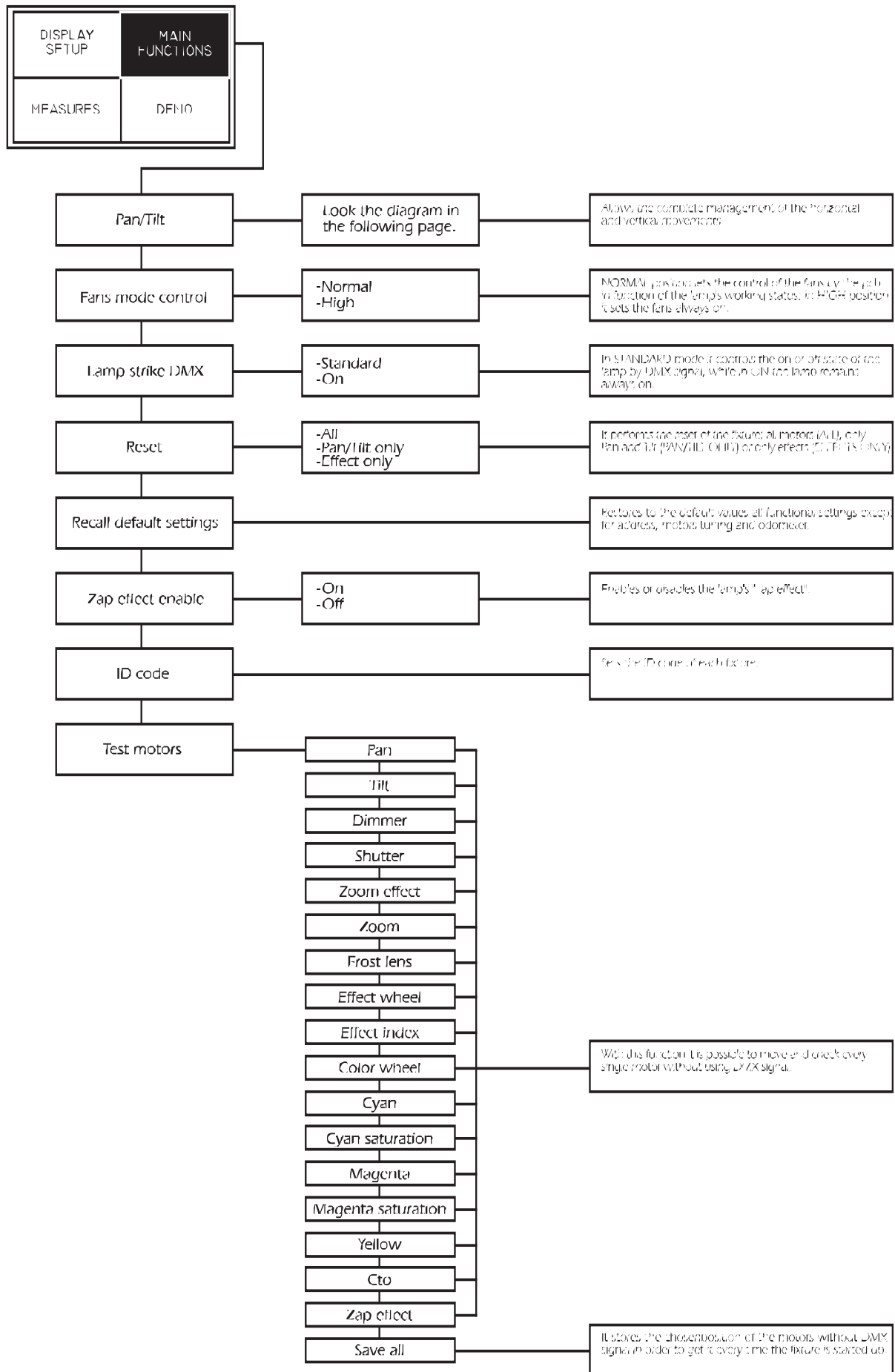

8.3. Main functions

The following diagram explains the sub menu for the management of pan and tilt, regarding the pan/tilt menu item described in the diagram at previous page.

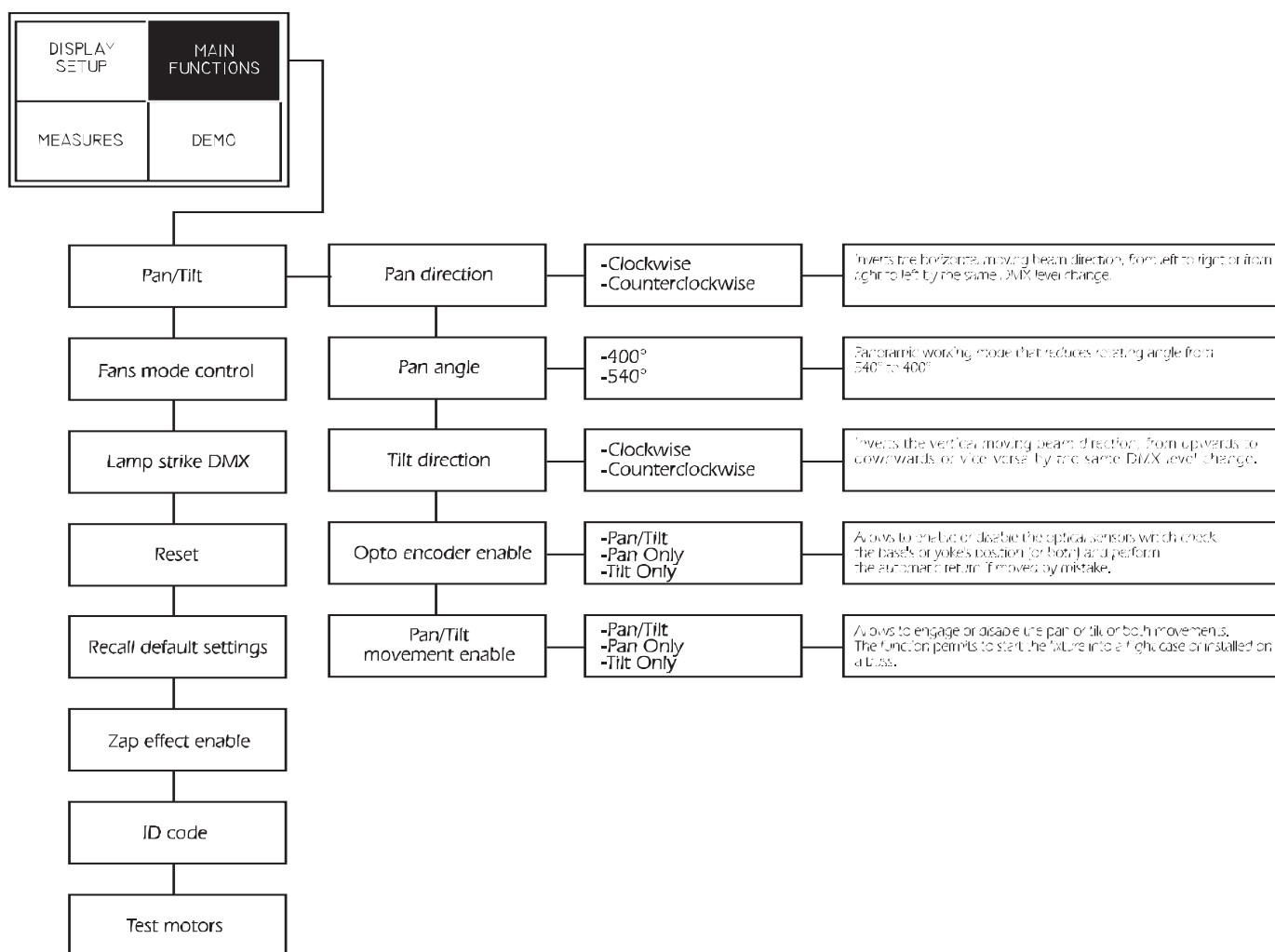

8.4. Measures

The internal microprocessor of the **Infinity Wash XL** allows for several diagnostic and output parameters to be displayed.

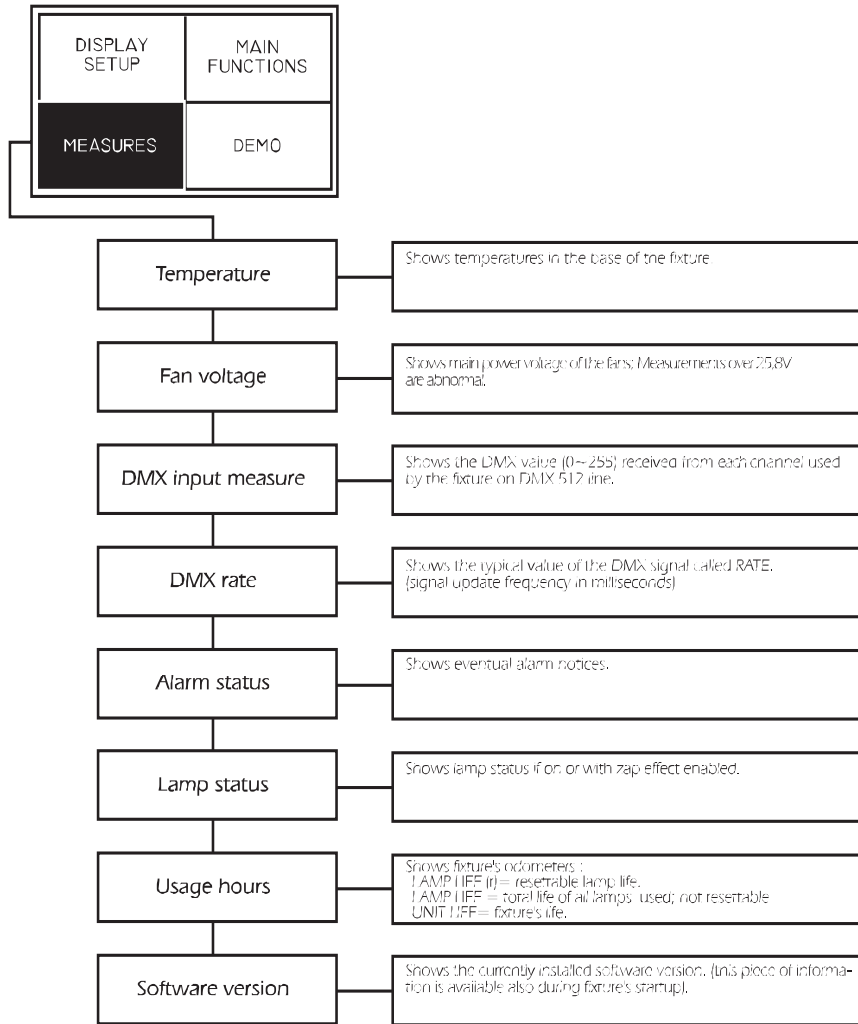

8.5. Display setup

The Display setup allows to tune the Infinity Wash XLs functions according to your needs. The following diagram shows the section's features.

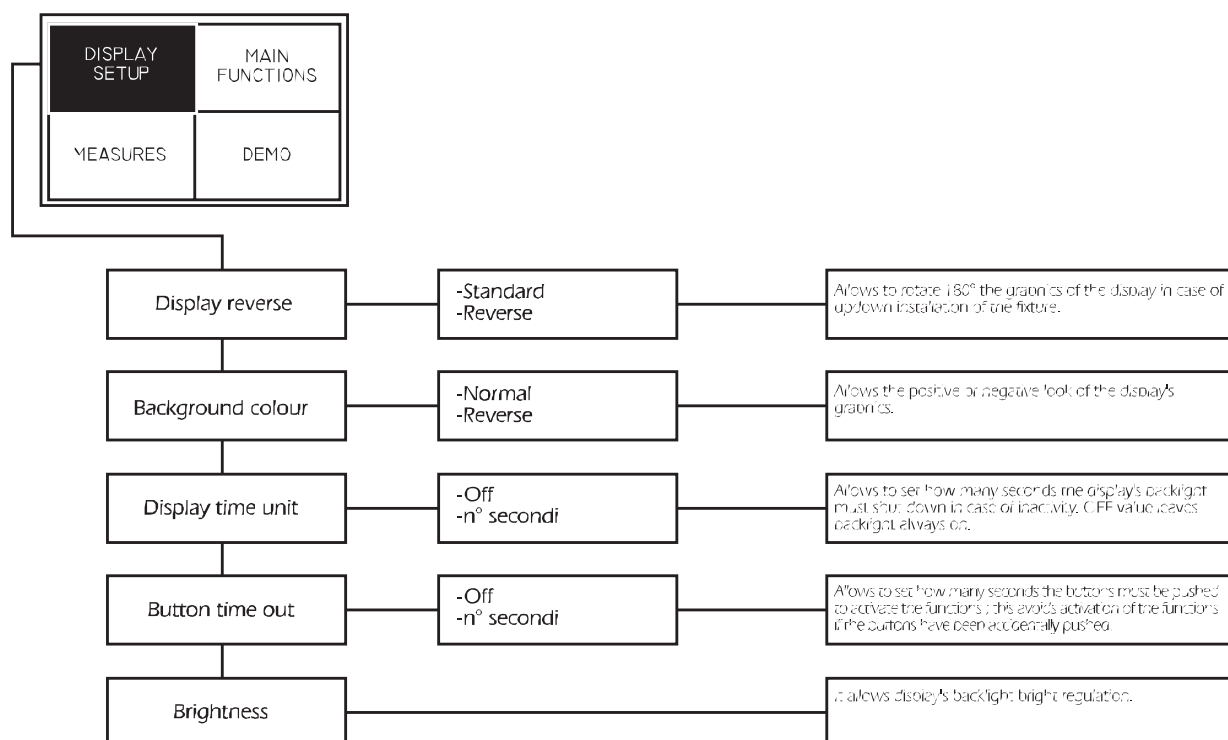

8.6. Demo mode

Demo mode allows the fixture to perform up to 4 different demonstration programs Infinity Wash XL.

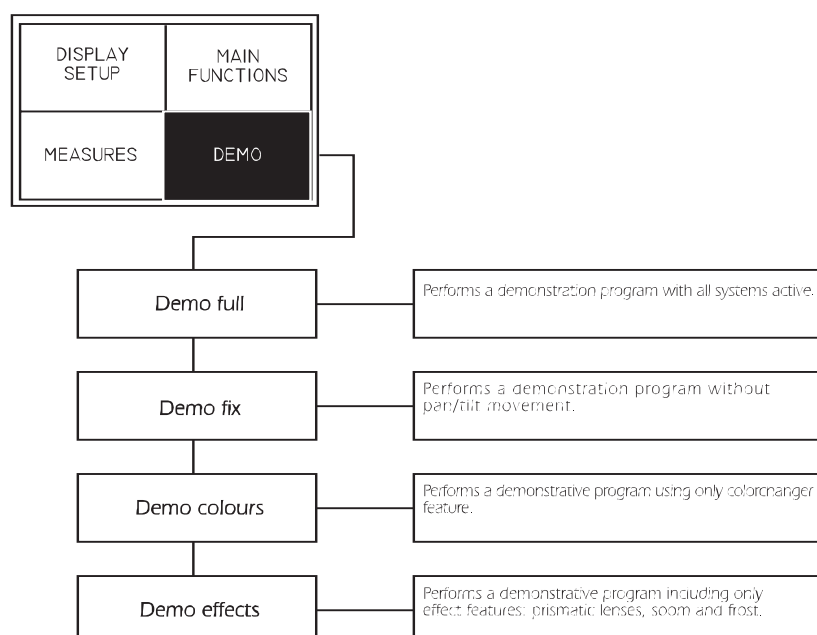

8.7. Special mode and electronic motors adjustment

ATTENTION!!

This procedure should only be undertaken by qualified and experienced technical personnel.

“SPECIAL MODE” menu allows the access to the motor adjustment section and to special functions like lamp odometer reset, software upload and download. To enter “SPECIAL MODE” reach the reset page in the “MAIN FUNCTIONS” menu, start reset choosing “ALL” and push simultaneously **enter** and **menu** button for 10 second nearly while the reset is being terminated.

WARNING!!

The electronic tuning procedure is only possible with DMX 512 signal present.

The display panel of the **Infinity Wash XL** allows for the electronic alignment of the projector’s motors in the optical system. This procedure is performed by **Coemar** at the factory. It may be useful to perform this procedure in the case of internal components being replaced.

Altering the factory settings may radically alter the functioning of the projector. Carefully read all of the following prior to attempting any changes.

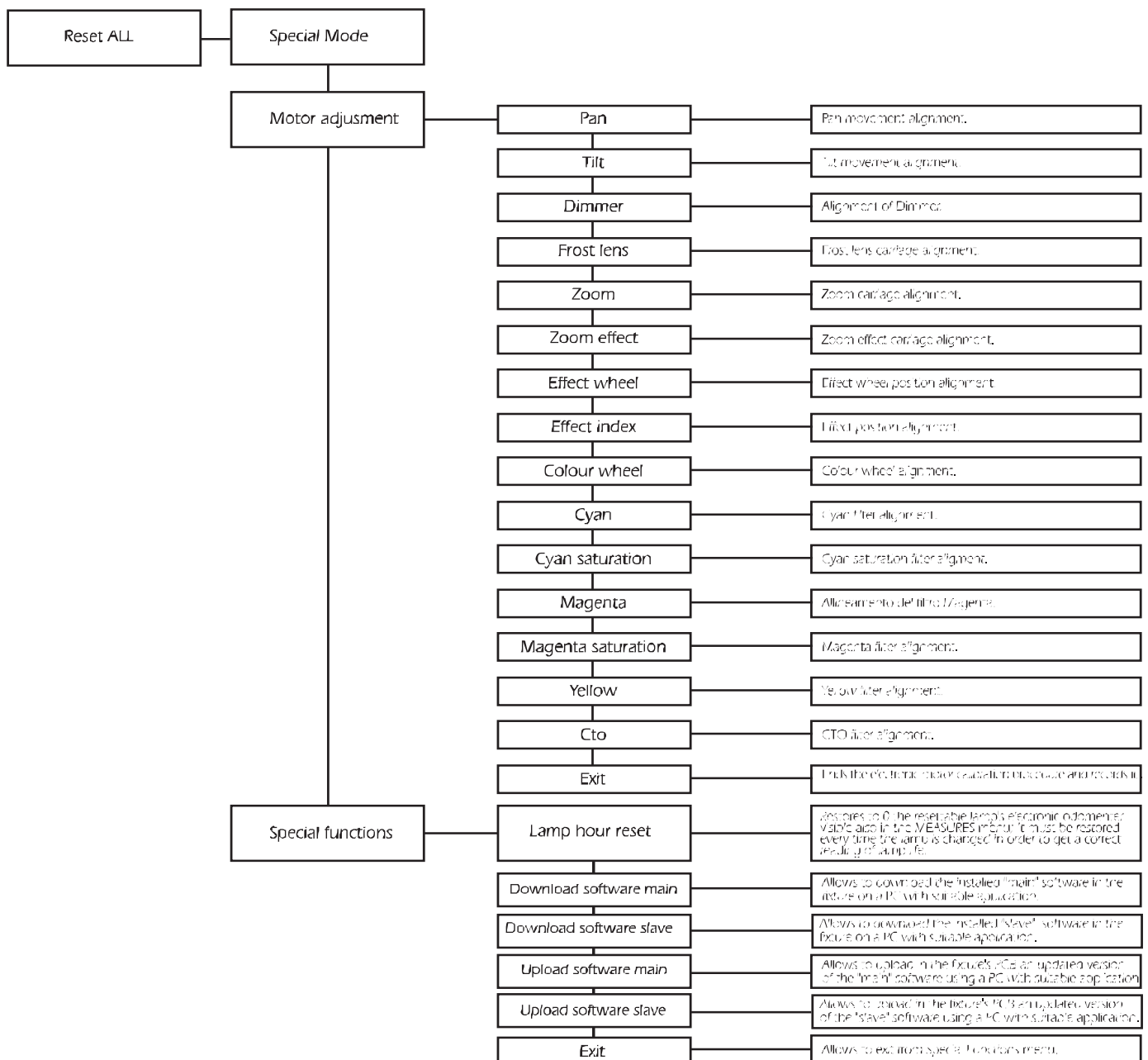

9. Lamp installation and alignment

The **Infinity WashXL** utilises the Philips MSR GOLD 1200 SA/SE FastFit with PGJ50 base lamps. The use power is 1400W. These lamps are available via your **Coemar** distributor or service centre.

Lamp	Philips MSR GOLD 1200 SA/SE FastFit
Coemar code	105817
Wattage Range	800 - 1400W
Lumen output at 1200W	95.000 lm
Colour temperature	6300° K
Base	PGJ50
Approximate lamp life	750 hours

ATTENTION!!

**Disconnct the unit from mains power prior to attempting lamp installation or replacement
Make sure the projector is sufficiently cooled.**

The fixture's internal temperature can reach 250° C after 5 minutes, with a maximum peak of 450° C; ensure that the lamp is cold prior to attempting removal. The fixture should be allowed to stand and cool for 10 minutes prior to its removal.

The lamps are part of the mercury vapour family of discharge lamps and must be handled with great care. The lamp operates at high pressure, and the slight risk of explosion of the lamp exists if operated over its recommended life. We recommend, therefore, that the lamp be replaced within the manufacturer's specified lamp life.

9.1. Lamp installation

1. Use a suitable tool to loosen the four screws "A" which affix the lampholder cover at the rear of the projector.

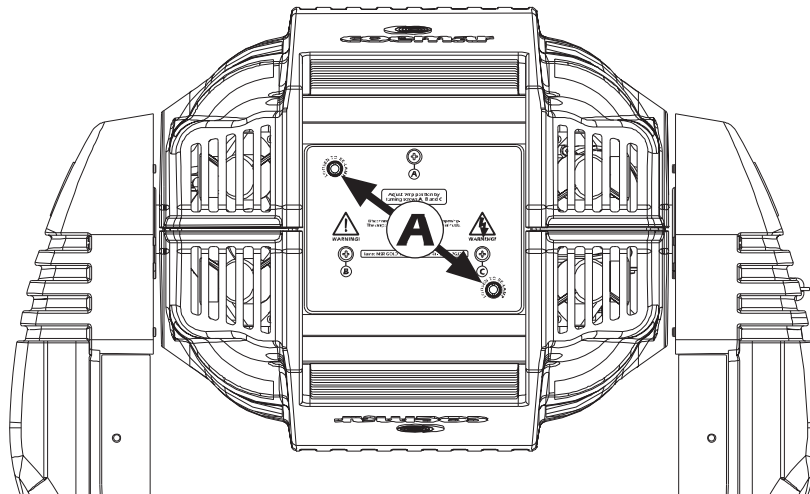

2. Remove the lampholder cover "B".

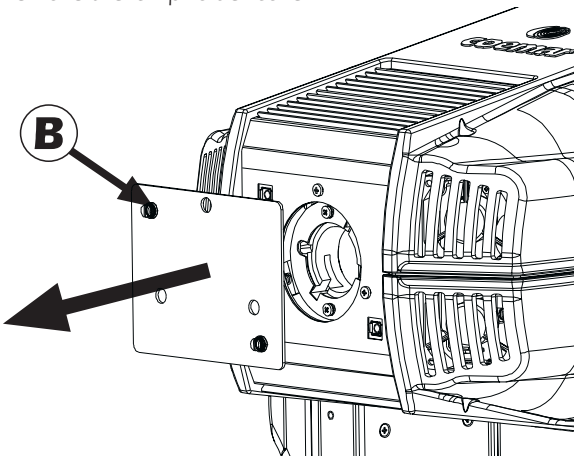

3. Identify the lampholder "C".

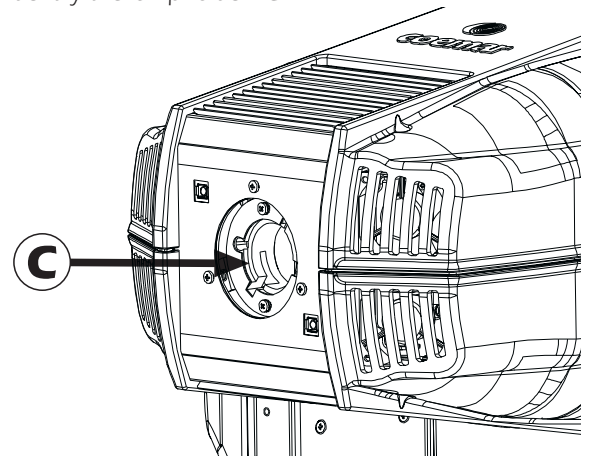

English

4. Insert the lamp and rotate clockwise.

The lamp used is manufactured from quartz glass and should be handled with care; always adhere to the instructions supplied in the lamp's packaging. Never touch the glass directly, use the tissue provided in the lamp's packaging. **DO NOT USE UNDUE FORCE.**

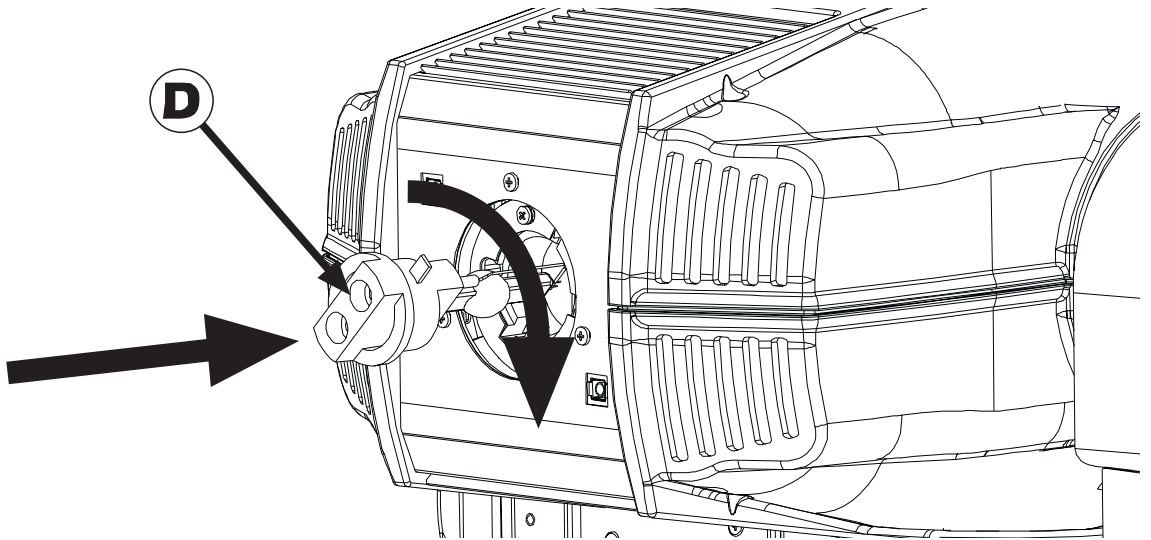

5. Replace the lampholder cover in its original position and refasten the two screws "A" which were previously removed.

ATTENTION!!

Each time you change the lamp, we recommend the following be carried out:

- realign the lamp in the optical path to avoid overheating dichroics and/or effects.
- reset the lamp life counter (as described in section 8.7. Resetting the counter).

9.2. Aligning the lamp in the optical path

Aligning the lamp in the optical system is achieved via the 3 adjusters at the rear of the projector. This procedure should be undertaken to maximise output, properly align the lamp in the optical system and to avoid the possible overheating of the internal components due to the incorrect focusing of the beam onto components not intended to be exposed to this.

Alignment procedure

Alignment is effected by the 3 adjusters **A**, **B** and **C** located on the lampholder assembly. The lamp should be on, black-out and dimmer fully open, and no colours selected. If the lamp is not correctly aligned, a hot-spot will be readily noticeable. Using the 3 adjusters in unison, you will need to bring the hot-spot to the centre of the beam and then flatten the beam to maximum uniformity.

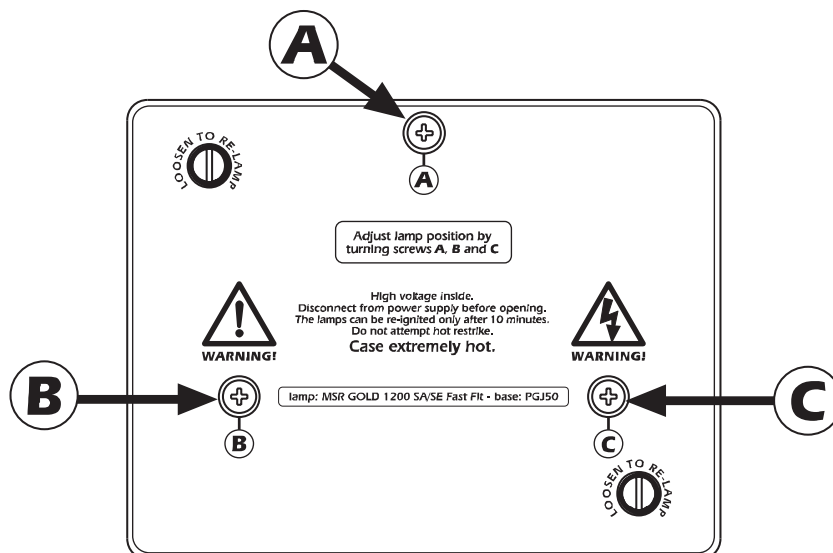

10. Removing the colour changer assembly

By removing the casing, complete access is available to the internals of the projector.

ATTENTION!!

Disconnct the unit from mains power prior to attempting lamp installation or replacement
Make sure the projector is sufficiently cooled.

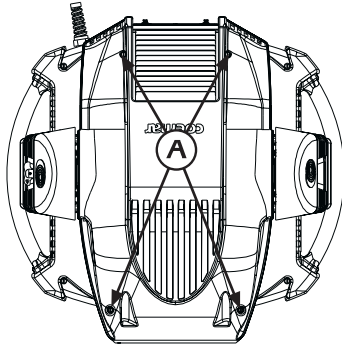

1. Using an appropriate screwdriver, remove the screws "A" which affix the housings and remove it.

To identify which part of the projector must be removed please position the unit so that the labels of the lampholder group are in the upright position. Now lock the unit by the locking device and remove the upper cover.

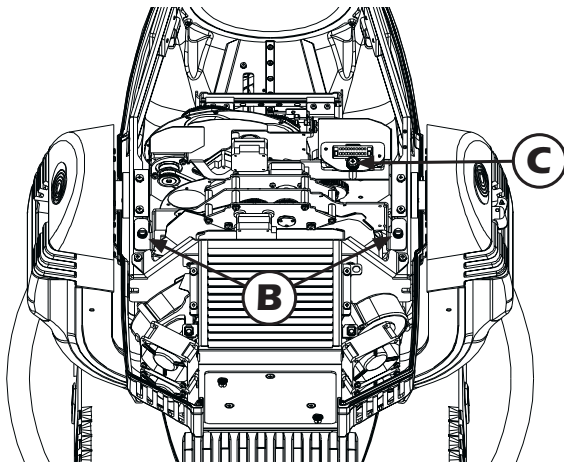

2. Using an appropriate screwdriver, remove the screws "B" which affix the colors changer and the connector "C".

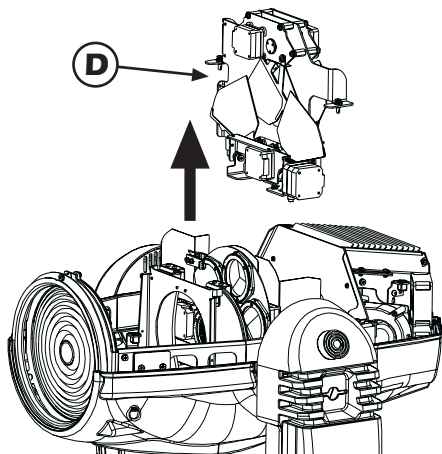

3. Remove the color changer assembly "D".
Now the assembly can be easily inspected.

ATTENTION!!

Handle with care the colour changer assembly to avoid damages on the dichroics filter.

5. Replace and fasten the assembly and the housings as per their original positions.

11. Maintenance

Whilst every possible precaution has been taken to ensure the trouble-free operation of your **Infinity Wash XL**, the following periodic maintenance is highly recommended.

ATTENTION!!

Always remove mains power and ensure the unit is sufficiently cooled prior to opening up the housing.

To gain access to the internals of the unit refer to chapter **10. Opening up the projector** of this manual.

11.1. Periodic cleaning

Lenses and reflectors

Even a fine layer of dust can reduce the luminous output substantially. Regularly clean all lenses and the reflector using a soft cotton cloth, dampened with a specialist lens cleaning solution.

Fans and air passages

The fans and air passages must be cleaned approximately every 6 weeks; the period for this periodic cleaning will depend, of course upon the conditions in which the projector is operating. Suitable instruments for performing this type of maintenance are a brush and a common vacuum cleaner or an air compressor.

11.2. Periodic maintenance

Lamp

Check the lamp and replacing it if there is any observable damage or deformation due to heat.

Mechanicals

Periodically check all mechanical devices for wear and tear; gears, guides, belts, etc., replacing them if necessary. Periodically check the lubrication of all components, particularly the parts subject to high temperatures. If necessary, lubricate with suitable lubricant, available from your **Coemar** distributor.

Electrical components

Check all electrical components for correct earthing and proper attachment of all connectors, refastening if necessary.

11.3. Fuse replacement

Locate the fuse, which protects the lamp and electronics, in the base of the **Infinity Wash XL**.

Using a multimeter, test the condition of the fuse, replacing it with one of equivalent type if necessary.

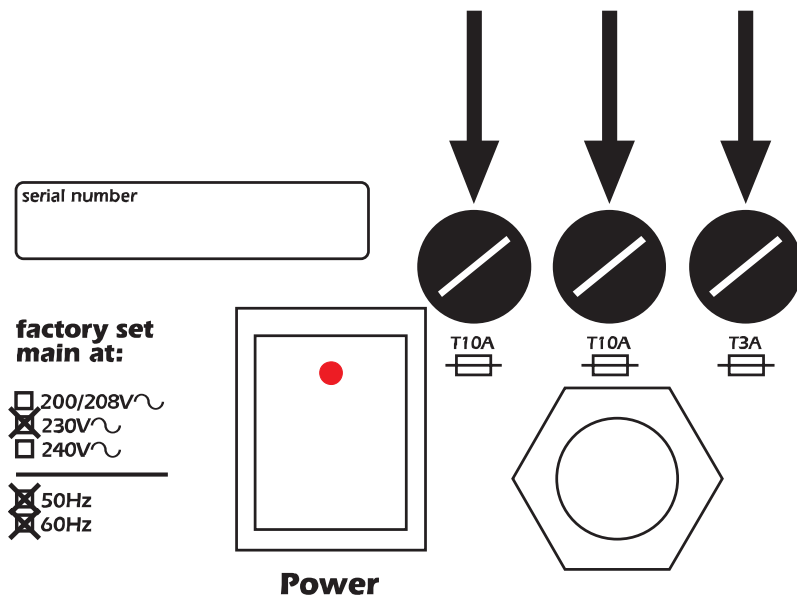

12. Spare parts

All the components of the **Infinity Wash XL** are available as replacement spares from your authorised **Coemar** service centre. Accurate description of the fixture, model number, and type will assist us in providing for your requirements in an efficient and effective manner.

13. Error messages

Error message	Description and solution
MEMORY FAILURE	EEPROM Error: The EEPROM is either absent or defective; refer to your Coemar service center for a replacement component
CFG data FAILURE	DATA Error: The initial parameter settings are incorrect or corrupted; the fixture has reloaded its factory default setting. Turn the fixture off and on again. Should the error reoccur, refer the unit to your authorised Coemar service center to have the EEPROM checked and possibly replaced.
No Slave LINK	COMMUNICATION Error: This message indicates that the motherboard within the unit is not communicating properly with the control source. Check the connectors located on both boards.
DMX address	DMX ADDRESSING Error: The fixture is not receiving all DMX channels needed to operate correctly. Check the DMX address indicated on the display and the channel numbers being outputted from the controller. Note that not all controllers will output all 512 channels.
DMX frame	DMX FRAME Error: DMX signal present but frame too short; the controller has not sufficient channels to drive Infinity Wash XL
Encoder PAN	PAN ENCODER Error: This messages indicates that there is a problem with the PAN encoders. Check the sensors on the encoder wheel located near the pan movement motor, as well as the relevant cabling.
Encoder TILT	TILT ENCODER Error: This message indicates that there is a problem with the TILT encoder located on the fixture's yoke. Check the sensors on the encoder wheel located near the tilt movement motor, as well as the relevant cabling..
Sensors line #5	Control circuit error relating to position sensors for 4 motors located upper in the yoke.(EFFECT). Check for the presence of power in the pcb and the condition of the connectors and cabling between the pcb and the sensors. Additionally, check motors and/or cogs for any impediments as well as the proper position of the cabling connectors.
Sensors line #1	Control circuit error relating to position sensors for 5 motors (ZOOM): Check for the presence of power to the pcb and the condition of the connectors and cabling between the pcb and the sensors. Additionally, check the motors and/or cogs for any impediments as well as the proper position of the cabling connector.
Sensors line #3	control circuit error relating to position sensors for 4 motors located lower in the yoke (COLOR WHEEL). Check for the presence of power to the pcb and the condition of the connectors and cabling between the pcb and the sensors. Additionally, check motors and/or cogs for any impediments as well as the proper position of the cabling connectors.
EFFECT wheel	Position error in EFFECT WHEEL sensor does not recognize magnet. Check the functioning and the correct positioning of the magnetic sensor of the effect wheel.
EFFECT index	Position error in EFFECT INDEXING: sensor does not recognize magnet Check the functioning and the correct positioning of the magnetic sensor of the effect indexing.
COLOR wheel	Position error in COLOR WHEEL: sensor does not recognize magnet Check the functioning and the correct positioning of the magnetic sensor of the colour wheel.
ZOOM effect	Position error in ZOOM EFFECT carriage: sensor does not recognize magnet Check the functioning and the correct positioning of the magnetic sensor of the zoom effect carriage.
ZOOM	Position error in ZOOM LENS: sensor does not recognize magnet Check the functioning and the correct positioning of the magnetic sensor of the zoom lens.
ZOOM shake	Position error in ZOOM LENS carriage: sensor does not recognize magnet Check the functioning and the correct positioning of the magnetic sensor of the zoom lens carriage.
LINE sync.	Network sync Error: Contact Coemar service center.
Slave Mem. FAIL.	Memory write Error motors pcb : Contact Coemar service center.

14. Frequently asked questions

Question	Possible cause	Possible solution
The projector is completely immobile.	Projector not powered up. The circuit breaker is switched off The protection fuse is blown	Check that the mains power cable is connected to power. Set the circuit breaker to ON. Disconnect the projector and replace the fuse.
The projector resets correctly, but either does not respond, or responds incorrectly, to DMX signal.	Incorrect signal connection Incorrect DMX address	Inspect the signal cable, rectify any incorrect wiring, repair or replace any damaged cables or connectors. Check the DMX address.
The lamp turns off intermittently	The projector is too hot.	Let the fixture cool down. Check that the air vents above the cooling fans are not obstructed and that the fans are working correctly. Ensure that the ambient temperature is below 35 °C. One of the fans does not work correctly and causes the overheating of the projector.



Coemar s.p.a.

via Inghilterra 2/A - 46042 Castel Goffredo (Mantova) Italy
ph. +39 0376/77521 - fax +39 0376/780657
info@coemar.com

Coemar si riserva il diritto di apportare modifiche senza preavviso.
Coemar reserves the right to effect modifications without notification