

---

# **ROBE**

---

**ROBIN<sup>®</sup> LEDBeam 350**

**ROBIN<sup>®</sup> LEDBeam 350 FW**

**ROBIN<sup>®</sup> LEDBeam 350 EP**

**ROBIN<sup>®</sup> LEDBeam 350 FW EP**

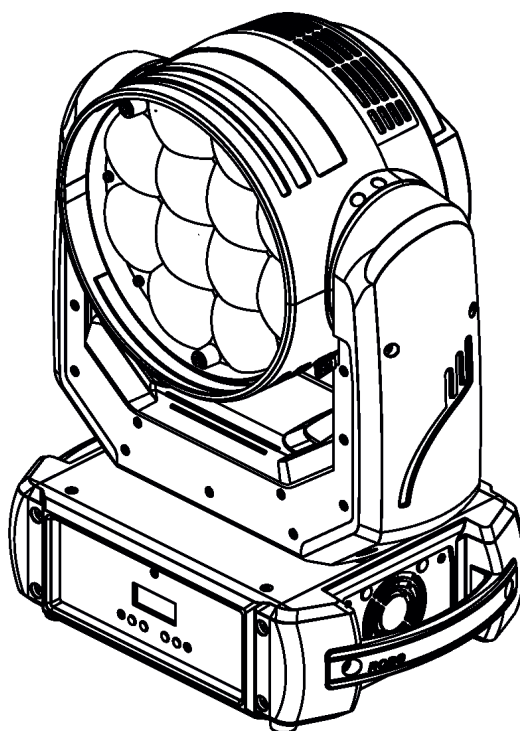

**ROBE**  
Innovative  
Technology

QR code for user manual



---

## **USER MANUAL**

---

ROBE<sup>®</sup> lighting s.r.o. • Czech Republic • [www.robe.cz](http://www.robe.cz)

Version 2.6

# ROBIN LEDBeam 350 ROBIN LEDBeam 350 FW ROBIN LEDBeam 350 EP ROBIN LEDBeam 350 FW EP

## Table of contents

<b>1. Safety instructions</b> .....	<b>3</b>
<b>2. Fixture exterior view</b> .....	<b>5</b>
<b>3. Installation</b> .....	<b>6</b>
3.1 Connection to the mains .....	6
3.2 Rigging the fixture .....	7
3.3 Eggcrate installation.....	9
3.4 Diffusion filter installation (LEDBeam 350/350 EP only) .....	10
3.5 DMX-512 connection.....	11
3.6 Ethernet connection (EP version only).....	12
3.7. Wireless DMX operation .....	13
<b>4. Control menu map</b> .....	<b>14</b>
<b>5. Control menu</b> .....	<b>17</b>
5.1 Addressing (DMXA).....	17
5.2 Fixture information (Info).....	17
5.3 Personality (Pers).....	18
5.4 Manual Control (Manual).....	20
5.5 Test program (Test Prg).....	20
5.6 Stand-alone (St Alone).....	20
5.7 Reset.....	21
5.8 Special functions (Special).....	21
<b>6. RDM</b> .....	<b>23</b>
<b>7. Error and information messages</b> .....	<b>24</b>
<b>8. Technical Specifications</b> .....	<b>25</b>
<b>9. Maintenance and cleaning</b> .....	<b>27</b>
9.1 Replacing fuse .....	27
<b>10. Photometric diagrams</b> .....	<b>28</b>
<b>11. ChangeLog</b> .....	<b>32</b>

**FOR YOUR OWN SAFETY, PLEASE READ THIS USER MANUAL CAREFULLY  
BEFORE POWERING OR INSTALLING YOUR ROBIN LEDBeam 350 !**

**Save it for future reference.**

This device has left our premises in absolutely perfect condition. In order to maintain this condition and to ensure a safe operation, it is absolutely necessary for the user to follow the safety instructions and warning notes written in this manual.

The manufacturer will not accept liability for any resulting damages caused by the non-observance of this manual or any unauthorized modification to the device.

Please consider that damages caused by manual modifications to the device are not subject to warranty.

**The ROBIN LEDBeam 350 was designed for indoor use and it is intended for professional application only. It is not for household use.**

## **1. Safety instructions**

**DANGEROUS VOLTAGE CONSTITUTING A RISK OF ELECTRIC SHOCK IS PRESENT WITHIN THIS UNIT!**

Make sure that the available voltage is not higher than stated on the rear panel of the fixture. This fixture should be operated only from the type of power source indicated on the marking label. If you are not sure of the type of power supplied, consult your authorized distributor or local power company.

Always disconnect the fixture from AC power before cleaning, removing or installing any part of the fixture.

The power plug has to be accessible after installing the fixture. Do not overload wall outlets and extension cords as this can result in fire or electric shock.

Do not allow anything to rest on the power cord. Do not locate this fixture where the cord may be damaged by persons walking on it.

Make sure that the power cord is never crimped or damaged by sharp edges. Check the fixture and the power cord from time to time.

Refer servicing to qualified service personnel.

**This fixture falls under protection class I. Therefore this fixture has to be connected to a mains socket outlet with a protective earthing connection.**

Do not connect this fixture to a dimmer pack.

**Warning! Risk Group 2 LED product according to EN 62471.  
LED light emission. Risk of eye injury. Do not look into the beam at short distance of the of the product.  
Do not view the light output with optical instruments or any device that may concentrate the beam.  
The light source contains blue LEDs.**

If the fixture has been exposed to drastic temperature fluctuation (e.g. after transportation), do not switch it on immediately. The arising condensation water might damage your device. Leave the device switched off until it has reached room temperature.

Avoid brute force when installing or operating the fixture.

This fixture was designed for indoor use only, do not expose this unit to rain or use near water.

When choosing the installation spot, please make sure that the fixture is not exposed to extreme heat, moisture or dust.

**Do not block the lens array with any object when the fixture is under operation.**

The cooling openings in head and base of the fixture should never be covered with cloth or other materials, and never must be blocked.

This fixture should not be placed in a built-in installation unless proper ventilation is provided.

Only operate the fixture after having checked that the housing is firmly closed and all screws are tightly fastened.

Always use a secondary safety wire for overhead installation of the fixture.

Make sure that the area below the installation place is blocked when rigging, derigging or servicing the fixture.

The fixture becomes hot during operation. Allow the fixture to cool approximately 15 minutes prior to manipulate with it.

Operate the fixture only after having familiarized with its functions. Do not permit operation by persons not qualified for operating the fixture. Most damages are the result of unprofessional operation!

Please use the original packaging if the fixture is to be transported.

Please consider that unauthorized modifications on the fixture are forbidden due to safety reasons!

If this device will be operated in any way different to the one described in this manual, the product may suffer damages and the guarantee becomes void. Furthermore, any other operation may lead to dangers like short-circuit, burns, electric shock, crash etc.

Immunity of the equipment is designed for electromagnetic environments E1, E2, E3 according to the standard EN55103-2 ed.2 Electromagnetic compatibility. Product family standard for audio, video, audiovisual and entertainment lighting control apparatus for professional use. Part 2: Immunity.

The product (covers and cables) must not be exposed to a high frequency electromagnetic field higher than 3V/m.

The installation company should check levels of possible interferences above the tested levels E1,E2,E3 given by this standard (e.g. transmitters in surrounding area) before installing the equipment.

Emission of the equipment complies with the standard EN55032 Electromagnetic compatibility of multimedia equipment – Emission Requirements according to class B.

**Potential foggy front lens array does not influence function of the fixture and does not subject to complaint.**

**To avoid damage of an internal optical system of the fixture, never let the sunlight (or other light source) lights directly to the lens array, even when the fixture is not working**

**Potential colour non-uniformity of the front lens array may occur, it does not influence colour output from the fixture and is not considered a fault.**

## 2. Fixture exterior view

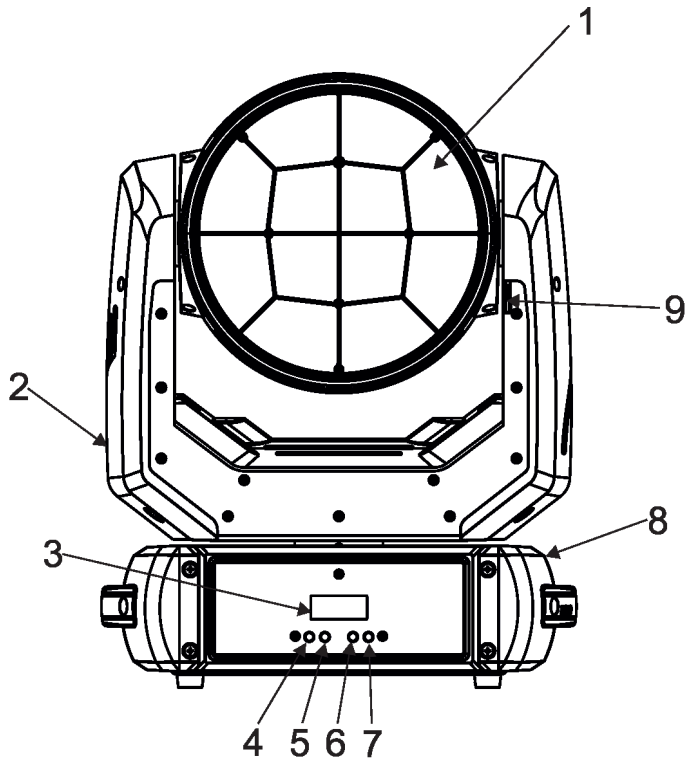

- 1 - Lens array
- 2 - Arm
- 3 - Display
- 4 - Escape button
- 5 - Enter button
- 6 - Next button
- 7 - Preview button
- 8 - Base
- 9 - Tilt lock

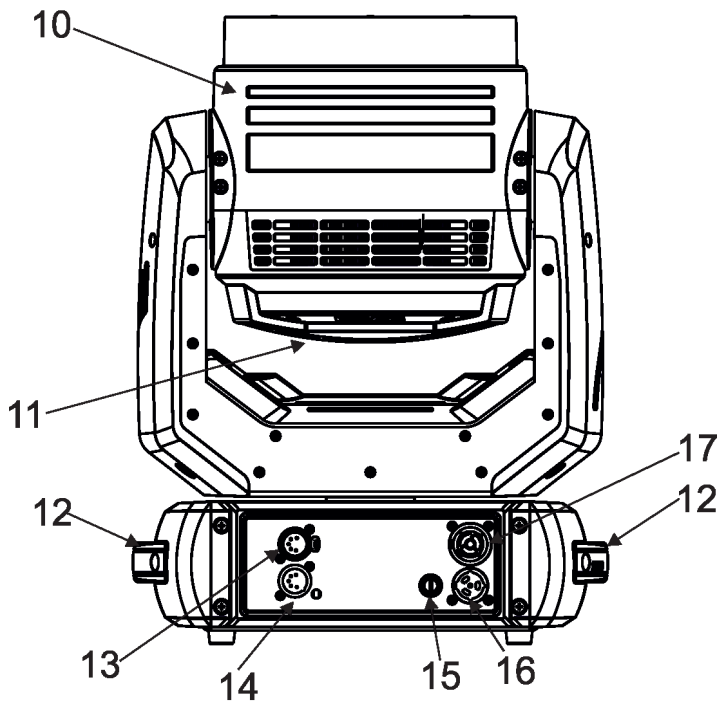

- 10 - Top head cover
- 11 - Rear Head cover
- 12 - Handle
- 13 - DMX Out (5-pin XLR)
- 14 - DMX In (5-pin XLR)
- 15 - Fuse holder
- 16 - Power In (PowerCon True 1)
- 17 - Power Out (PowerCon True 1)

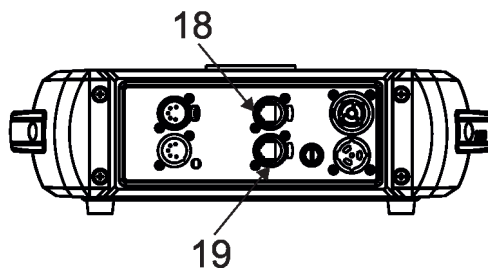

- EP version only**
- 18 - Ethernet In
  - 19 - Ethernet Out

### 3. Installation



**Fixtures must be installed by a qualified electrician in accordance with all national and local electrical and construction codes and regulations.**

#### 3.1 Connection to the mains

**For protection from electric shock, the fixture must be earthed!**

The ROBIN LEDBeam 350 is equipped with auto-switching power supply that automatically adjusts to any 50-60Hz AC power source from 100-240 Volts.

If you need to install a power plug on the power cable to allow connection to power outlets, install a ground-type (earthed) plug following the plug manufacturer's instructions. If you have any doubts about proper installation, consult a qualified electrician.

Core (EU)	Core (US)	Connection	Plug Terminal Marking
Brown	Black	Live	L
Light blue	White	Neutral	N
Yellow/Green	Green	Earth	

**The device falls under class one and must be earthed (grounded)!**

Design of the ROBIN LEDBeam 350 allows to connect several fixtures to AC mains power in one interconnected daisy chain using power input and throughput connectors. Needed daisy chain cords are stated in the chapter "Technical specifications"

The fixture head has to be locked for transportation - the tilt lock latch (9) has to be in locked position. To unlock the head, move the latch to unlock position before operating the fixture.

The max. number of connected fixtures depends on the AC mains power voltage:

CE:

7 fixtures at power supply= 230V

7 fixtures at power supply= 208V

4 fixtures at power supply= 120V

US:

6 fixtures at power supply= 230V

5 fixtures at power supply= 208V

3 fixtures at power supply= 120V

Real numbers of fixtures may differ from values stated above as you have to take into account the length of supply cables, circuit breaker etc. at projecting of the fixtures installation Do not overload the supply line and connecting leads.

Wiring and connection work must be carried out by qualified staff!

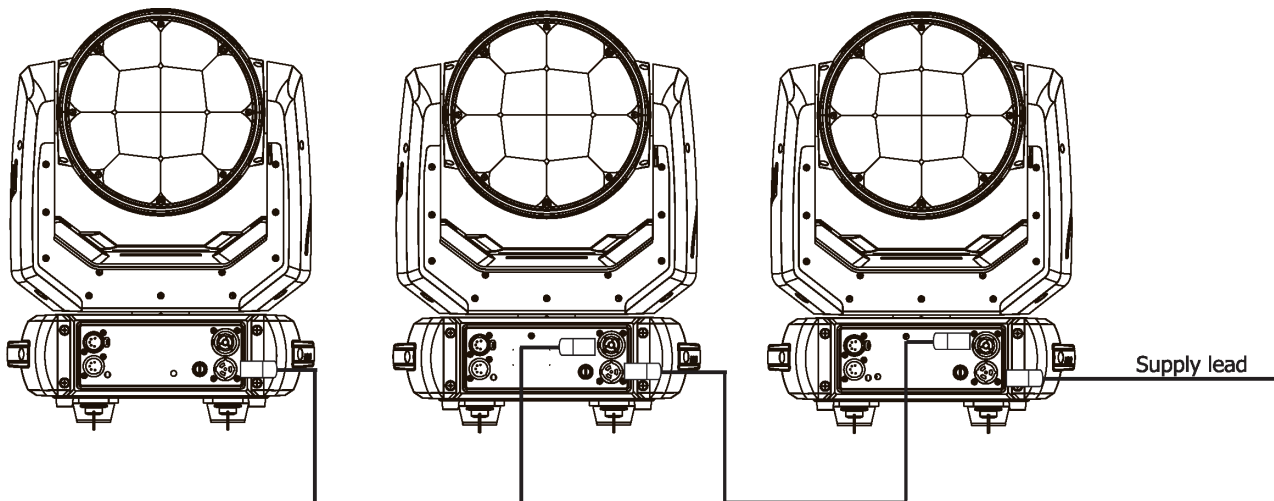

## 3.2 Rigging the fixture

The installation of the fixture has to be built and constructed in a way that it can hold 10 times the weight for 1 hour without any harming deformation.

The installation must always be secured with a secondary safety attachment, e.g. an appropriate catch net. This secondary safety attachment must be constructed in a way that no part of the installation can fall down if the main attachment fails.

When rigging, derigging or servicing the fixture staying in the area below the installation place, on bridges, under high working places and other endangered areas is forbidden.

The operator has to make sure that safety-relating and machine-technical installations are approved by an expert before taking into operation for the first time and after changes before taking into operation another time.

The operator has to make sure that safety-relating and machine-technical installations are approved by an expert after every four year in the course of an acceptance test.

The operator has to make sure that safety-relating and machine-technical installations are approved by a skilled person once a year.

The fixture should be installed outside areas where persons may walk by or be seated.

**IMPORTANT! OVERHEAD RIGGING REQUIRES EXTENSIVE EXPERIENCE**, including (but not limited to) calculating working load limits, installation material being used, and periodic safety inspection of all installation material and the projector. If you lack these qualifications, do not attempt the installation yourself, but instead use a professional structural rigger. Improper installation can result in bodily injury or damage to property. The fixture has to be installed out of the reach of people.

If the fixture shall be lowered from the ceiling or high joists, professional trussing systems have to be used. The fixture must never be fixed swinging freely in the room.

**Caution:** Fixture may cause severe injuries when crashing down! If you have doubts concerning the safety of a possible installation, do not install the moving head!

Before rigging make sure that the installation area can hold a minimum point load of 10 times the fixture's weight.

**When installing the device, make sure there is no highly inflammable material (decoration articles, etc.) in a distance of min. 0.4 m.**

**CAUTION!**  
**Use an appropriate clamp to rig the fixture on the truss.**  
**Follow the instructions mentioned at the bottom of the base.**  
**Make sure that the device is fixed properly! Ensure that the structure (truss) to which you are attaching the fixtures is secure.**

The fixture can be placed directly on the stage floor or rigged in any orientation on a truss without altering its operation characteristics .

For securing the fixture to the truss, install a safety wire which can hold at least 10 times the weight of the fixture. Use only the safety wire with a snap hook with screw lock gate.

## Truss installation

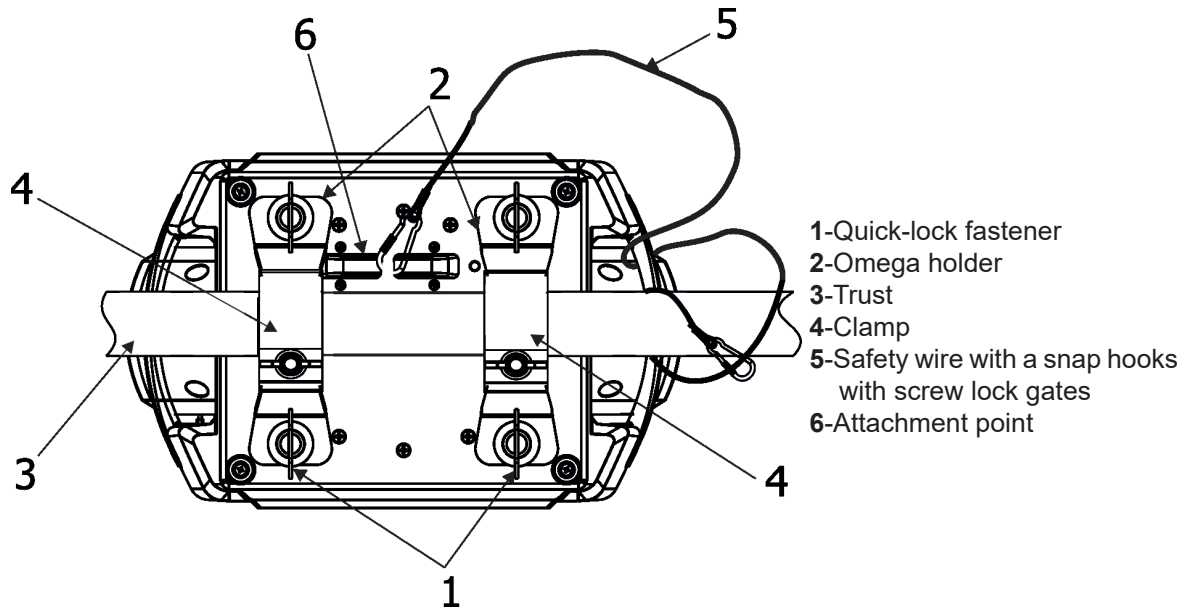

1. Bolt each clamp (1) to the omega holder (2) with M12 bolt and lock nut through the hole in the holder.
2. Fasten the omega holders to the bottom of the base by inserting both quick-lock fasteners (1) into the holes of the base and tighten fully clockwise.
3. Clamp the fixture on a truss (3) and tighten the rigging clamps.
4. Pull a safety wire (5) through the carrying handle and the truss (3) as shown on the picture above in a suitable position so that the maximum fall of the fixture will be 20 cm. Fasten a snap hook in the attachment point (6). Use only the safety wire with a snap hooks with screw lock gates.

**When installing fixtures side-by-side, avoid illuminating one fixture with another!**



### 3.3 Eggcrate installation

**Disconnect the fixture from mains before installing the eggcrate .**

1. Unscrew three screws M3x8 (1) which hold safety locks (2) of the lens array. Remove the safety locks (2).
2. Insert the eggcrate (3) on the lens array and screw it to the lens array by means of the three enclosed screws M3x10 (4).

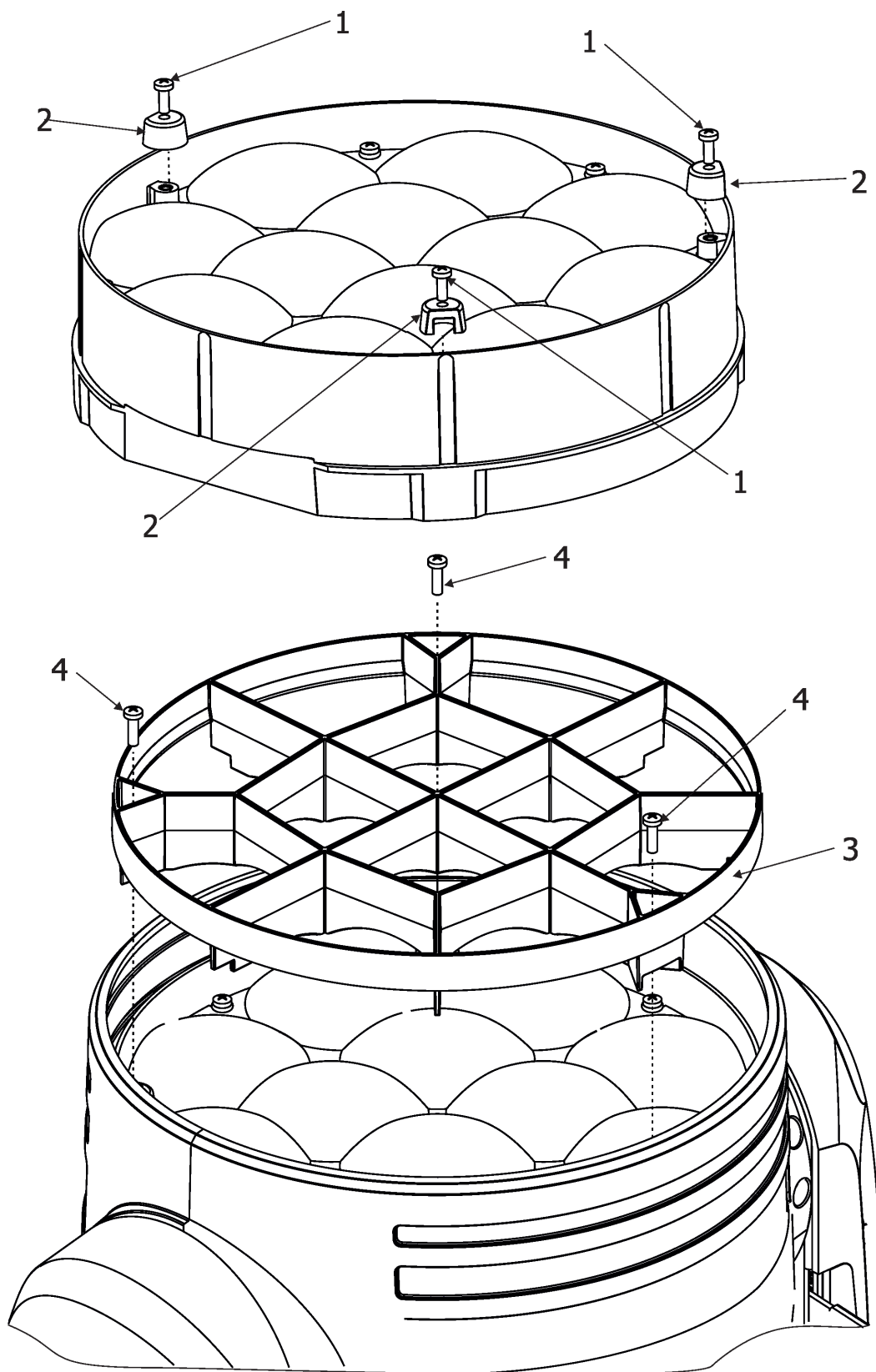

### 3.4 Diffusion filter installation (LEDBeam 350/350 EP only)

**Disconnect the fixture from mains before installing the eggcrate .**

1. Unscrew three screws M3x8 (1) which hold safety locks (2) of the lens array and remove them.
2. Unscrew the five screws M3x12 (3) with rubber rings (4) and remove the lens array (5) and the plastic film (6).
3. Remove transport protecting foil(s) from the diffusion filter.
4. Insert diffusion filter (7) matt side towards the lens array (5).
5. Insert the plastic film (6).
6. Insert the lens array (5) and screw it by means of the five screws (3) with rubber rings (4).
- IMPORTANT: Screws (5) have to be tightened in this way that rubber rings (4) are slightly deformed. Do not tighten them excessively, there is a risk of lens array cracking .**
7. Insert the three safety locks (2) on the lens array (5) and screw them by means of the three screws M3x8 (1).
8. Check that all screws are screwed and tightened.

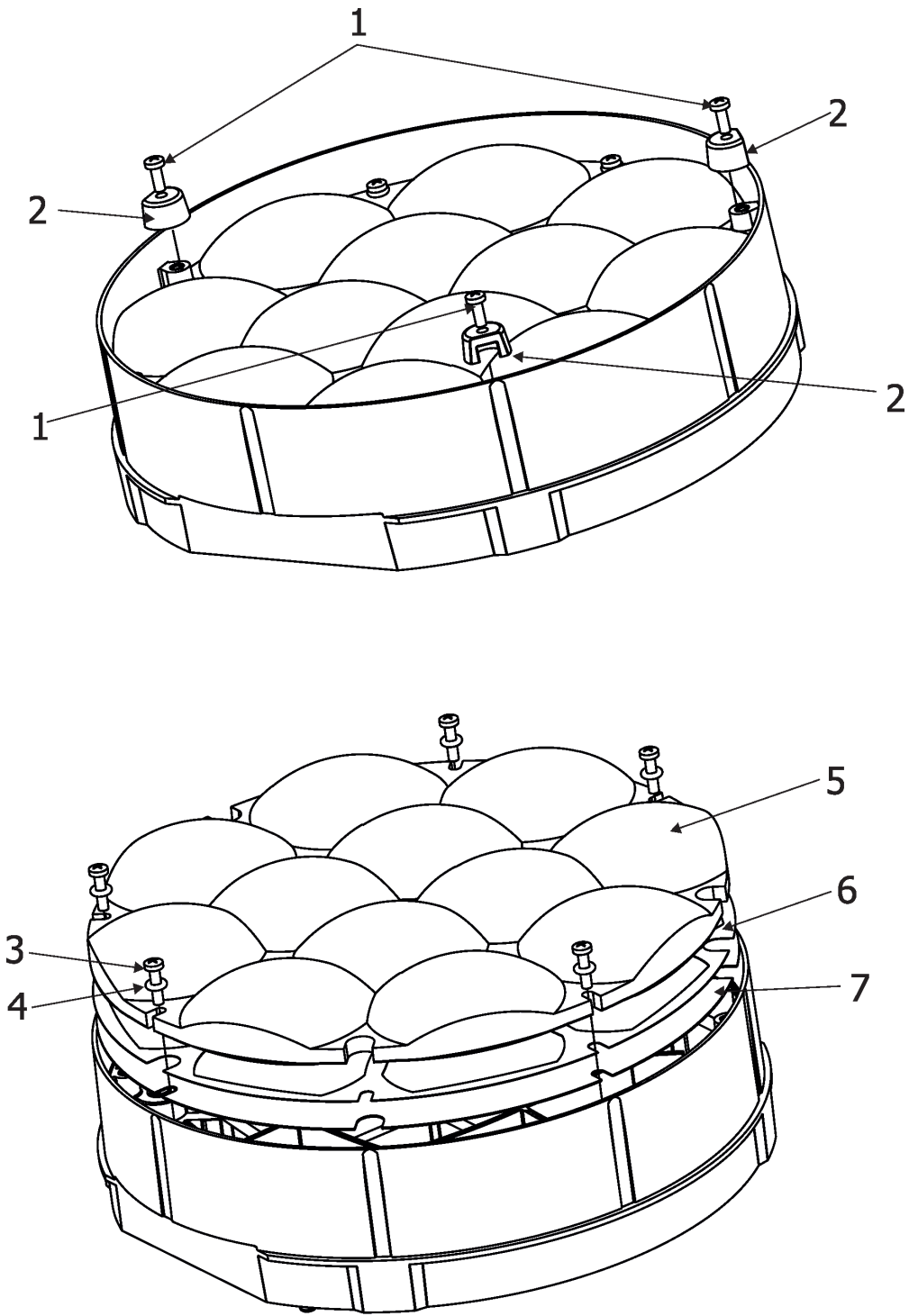

### 3.5 DMX-512 connection

The fixture is equipped with 5-pin XLR sockets for DMX input and output. Only use a shielded twisted-pair cable designed for RS-485 and 5-pin XLR plugs and connectors in order to connect the controller with the fixture or one fixture with another.

#### DMX output

XLR socket:



- 1 - Shield
- 2 - Signal (-)
- 3 - Signal (+)
- 4 - Used for wireless DMX
- 5 - Used for wireless DMX

#### DMX input

XLR plug:



- 1 - Shield
- 2 - Signal (-)
- 3 - Signal (+)
- 4 - Used for wireless DMX
- 5 - Used for wireless DMX

If you are using the standard DMX controllers, you can connect the DMX output of the controller directly with the DMX input of the first fixture in the DMX chain. If you wish to connect DMX controllers with other XLR outputs, you need to use adapter-cables.

#### Building a serial DMX chain:

Connect the DMX output of the first fixture in the DMX-chain with the DMX input of the next fixture. Always connect one output with the input of the next fixture until all fixtures are connected. Up to 32 fixtures can be interconnected.

**Caution:** At the last fixture, the DMX cable has to be terminated with a terminator. Solder a 120 Ω resistor between Signal (-) and Signal (+) into a 5-pin XLR plug and plug it in the DMX output of the last fixture.

Example of connection:

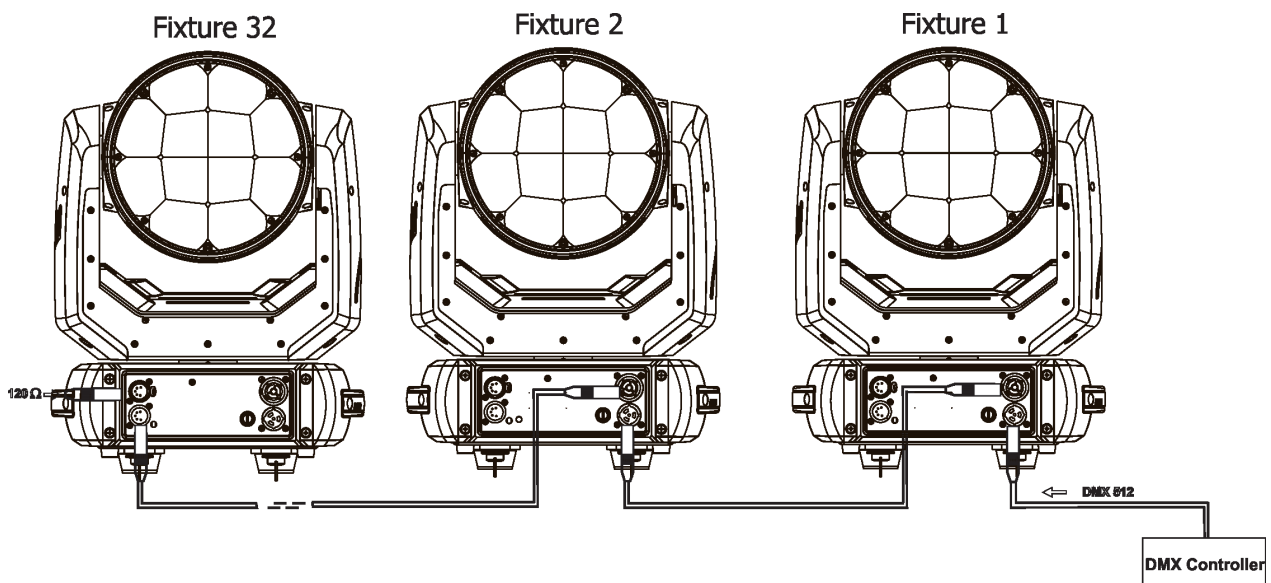

### 3.6 Ethernet connection (EP version only)

The fixtures on a data link are connected to the Ethernet with appropriate communication protocol (e.g. ArtNet). The control software running on your PC (or light console) has to support this communication protocol. Art-Net communication protocol is a 10 Base T Ethernet protocol based on the TCP/IP. Its purpose is to allow transfer of large amounts of DMX 512 data over a wide area using standard network technology.

**The IP address** is the Internet protocol address. The IP uniquely identifies any node (fixture) on a network.  
**The Universe** is a single DMX 512 frame of 512 channels.

The Robin LEDBeam 350 EP is equipped with 8-pin RJ-45 sockets for Ethernet connection. Use a network cable category 5 (with four "twisted" wire pairs) and standard RJ-45 plugs in order to connect the fixture to the network.

**RJ-45 socket (front view):**

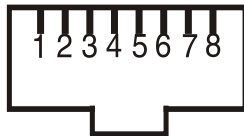

- |                  |                  |
|------------------|------------------|
| 1- TD+           | 5- Not connected |
| 2- TD-           | 6- RX-           |
| 3- RX+           | 7- Not connected |
| 4- Not connected | 8- Not connected |

**RJ-45 plug (front view):**

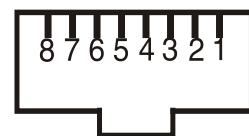

Patch cables that connect fixtures to the hubs or LAN sockets are wired 1:1, that is, pins with the same numbers are connected together:

- |     |     |     |     |     |     |     |     |
|-----|-----|-----|-----|-----|-----|-----|-----|
| 1-1 | 2-2 | 3-3 | 4-4 | 5-5 | 6-6 | 7-7 | 8-8 |
|-----|-----|-----|-----|-----|-----|-----|-----|

If only the fixture and the computer are to be interconnected, no hubs or other active components are needed. A cross-cable has to be used:

- |     |     |     |     |     |     |     |     |
|-----|-----|-----|-----|-----|-----|-----|-----|
| 1-3 | 2-6 | 3-1 | 4-8 | 5-7 | 6-2 | 7-5 | 8-4 |
|-----|-----|-----|-----|-----|-----|-----|-----|

Connect the Ethernet inputs of all fixtures to the Ethernet network. Set their IP addresses and Net Masks. Correct communication protocol (e.g. "ArtNet") has to be selected from the menu "Eth Mode" in the fixtures (Pers-->Ethernet -->Eth Mode). Set Universe(s) according to communication protocol.

Example of connection:

- |   |  |  |   |
|---|--|--|---|
| (DMX address=177)<br>IP address=002.168.002.008<br>Universe=1 | (DMX address=45)<br>IP address=002.168.002.004<br>Universe=1 | (DMX address=23)<br>IP address=002.168.002.003<br>Universe=1 | (DMX address=1)<br>IP address=002.168.002.002<br>Universe=1 |
|---|--|--|---|

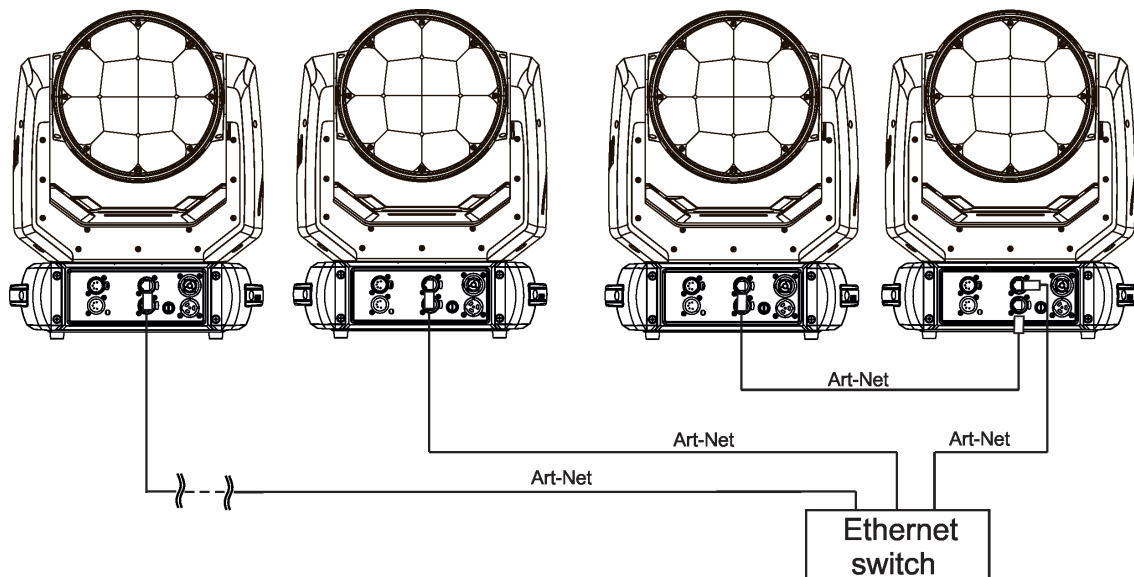

An advised PC setting: IP address: 002.xxx.xxx.xxx (Different from fixtures IP addresses)  
 NET mask: 255.0.0.0

The EP version of the fixture is equipped with Ethernet Pass Through Switch which sustains Ethernet integrity, when the fixture has no power, it automatically maintains network connectivity.

If you use the Ethernet IN-OUT way for the Ethernet connection, max. 8 fixtures can be connected in the IN-OUT line.

### 3.7. Wireless DMX operation

The external ROBE Wireless CRMX Dongle allows receiving wireless DMX. This device is equipped with the Lumen Radio CRMX module and antenna for receiving DMX signal. CRMX module operates on the 2.4 GHz band.

ROBE Wireless CRMX Dongle

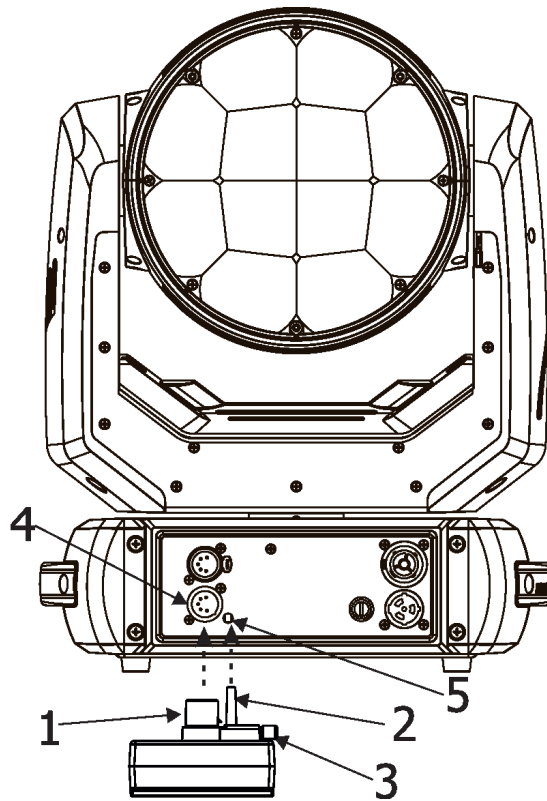
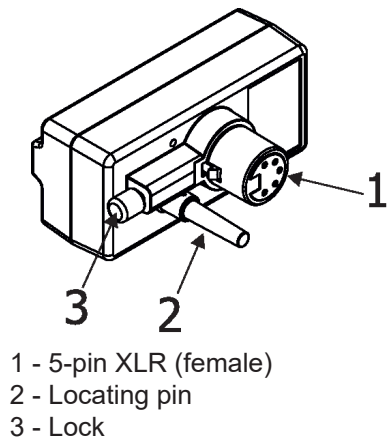

Push in the 5-pin XLR plug (1) into 5-pin XLR socket (4) and simultaneously locating pin (2) into hole (5) in the fixture. In this way the wireless DMX module is connected with the fixture.

NOTE: when you disconnect the DMX wireless module from fixture, press and hold lock (5) during getting the wireless module out.

#### To link the fixture with DMX transmitter.

The fixture can be only linked with the transmitter by running the link procedure at DMX transmitter .

After linking , the level of DMX signal ( 0-100 %) is displayed in the menu item "Stat" (Special -->Wireless -->Stat).

#### To unlink the fixture from DMX transmitter.

The fixture can be unlinked from transmitter via the menu item " Unlink" (Special-->Wireless -->Unlink.).

## 4. Control menu map

Default settings=**Bold print**

Level 1	Level 2	Level 3	Level 4	Level 5	Level 6	Level 7	
<b>DMXA</b>	Set DMXA	001-512					
	DMX Pres	Mode 1					
		Mode 2					
		<b>Mode 3</b>					
	IP Addr*	Def addr	Apply				
		Cus addr	IP 1	0-255			
			IP 2	0-255			
			IP 3	0-255			
			IP 4	0-255			
			Set Address				
	Net Mask*	N.M. 1	0-255				
		N.M. 2	0-255				
		N.M. 3	0-255				
		N.M. 4	0-255				
		Set Net M.					
	<b>Info</b>	IP Addr*	IP A. 1				
			IP A. 2				
		IP A. 3					
		IP A. 4					
MAC Addr*		MAC A. 1					
		MAC A. 2					
		MAC A. 3					
		MAC A. 4					
		MAC A. 5					
		MAC A. 6					
POn Time		Total					
		Reset					
LOTi							
		R LOTi					
		G LOTi					
		B LOTi					
		W LOTi					
Air fil		Aler P	10-300				
		R Ti					
DMX In		Pan	0-255				
		:					
		Dimm F	0-255				
Hea Temp		Current					
		Highest					
		High Res					
Sw Ver		IC-1					
		IC-2					
	IC-3						
	IC-4						
<b>Pers</b>	Ethernet*	Eth Mode	ArtNet				
			sACN				
			gMA I				
			gMA II				
		ArtNet	Uni	0-255			
		sACN	Uni	1-63999			
		MANet	Uni	1-256			

Level 1	Level 2	Level 3	Level 4	Level 5	Level 6	Level 7
		MANet	IsIDi	1-32		
		IGMP r	Off, 1-10s			
	DMX Pres	Mode 1				
		Mode 2				
		<b>Mode 3</b>				
	Pan Rev	On, <b>Off</b>				
	Tilt Rev	On, <b>Off</b>				
	P/T Mode	<b>Speed</b>				
		Time				
	P/T Feed	<b>On, Off</b>				
	Pan range	<b>Standard</b>				
		Reduced				
	Display	Turn				
		On/Off T	<b>On, Off</b>			
		Contrast	0-100%			
		Backlight	0-100%			
	BLC DMC	On, <b>Off</b>				
	BLC P/T	On, <b>Off</b>				
	Mic Sens	0... <b>10</b> ...19				
	Fans	Fans Mode	<b>Auto, High, Quiet</b>			
		BLC Fans				
		Noise L.	0-100%			
	Col Mix	<b>RGBW, CMY</b>				
	White P	<b>On, Off</b>				
	Dimmer C	<b>Square, Linear</b>				
	LED Freq	<b>Stand</b>				
		High				
	LED Fadj	-06,-05..00..05, 06				
	Temp Uni	<b>°C, °F</b>				
	I Ef Pos	Pan				
		:				
		Dim F				
		Store				
	Defaults					
<b>Manual</b>	Pan	0-255				
	:					
	Dimm F	0-255				
<b>Test Prg</b>	Static	Pan	0-255			
		Tilt	0-255			
		Run				
	Dynamic					
<b>Sta Alone</b>	Music T	On, <b>Off</b>				
	Auto Run	<b>Off</b>				
		Test				
		Prog 1				
		Prog 2				
		Prog 3				
	Pr Play	Test Prg				
		Prog 1				
		Prog 2				
		Prog 3				
	Pr Edit	Prog 1	Step 1	Pan		
		Prog 2	:	:		
		Prog 3	Step 40	F.Tim	0-25.5	

Level 1	Level 2	Level 3	Level 4	Level 5	Level 6	Level 7
				S.Tim	0-25.5	
				COPY		
				Prg End	1-40	
<b>Reset</b>						
<b>Special</b>	RDM Low					
	RDM Hight					
	Wireless	Stat				
		Unlink				
	Adjust	DMX Val	Pan	0-255		
			:			
			Dimm F	0-255		
		Clalib	Cal Mech	Pan C	0-255	
				Tilt C	0-255	
				Zoom C	0-255	
				Store		
			Cal Col	Red C	R X, R Y, R I, R T	
				Gre C	G X, G Y, G I, G T	
				Blu C	B X, B Y, B I, B T	
				Whi C	W X, W Y, W I, W T	
				Store		
			Cal Load			
	Sw Upd	On, <b>Off</b>				

\* LEDBeam 350 RGBA EP version only



## 5. Control menu

The ROBIN LEDBeam 350 is equipped with 2-row LCD display which allows to set the fixture's behaviour according to your needs, obtain information on its operation, test its various parts and lastly program it, if it has to be used in a stand-alone mode.

Control panel:

[ESCAPE] button used to leave the menu without saving changes.

[NEXT] , [PREV] buttons for moving between menu items and for value adjusting.

[ENTER] button used to enter the selected menu (menu item) and to confirm adjusted value.

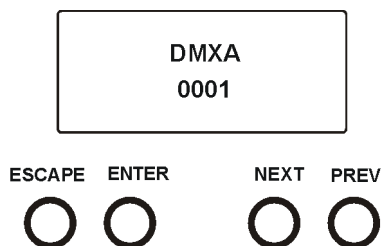

After switching the fixture on, display shows current DMX address.

### 5.1 Addressing (DMXA)

**Set DMXA** - Use this menu item to set the DMX start address of the fixture, which is defined as the first channel from which the ROBIN LEDBeam 350 will respond to the controller.

If you set, for example, the address 23, the ROBIN LEDBeam 350 will use channels 23 - 44 for control (if Mode 1 is selected).

Please, be sure that you do not have any overlapping channels in order to control each ROBIN LEDBeam 350 correctly and independently from any other fixture on the DMX data link.

If there is no data received at the DMX input, the display will start to flash "0001" with actually stored DMX address.

**DMX Pres** - **DMX preset**. Use the menu to select desired channel mode.

**Mode 1** - 22 control channels

**Mode 2** - 16 control channels

**Mode 3** - 24 control channels

**IP Addr\*** - **IP address**. Use the menu item to set desired IP address. IP address is the Internet protocol address. The IP uniquely identifies any node (fixture) on a network. There cannot be 2 fixtures with the same IP address on the network!

**Def addr** - **Default IP address**. This address is derived from fixture's MAC address and cannot be changed. Confirm the item "**Apply**" to select this address.

**Cus addr** - **Custom address**. IP address consists of four decimal numbers, each ranging from 0 to 255, separated by dots, e.g. 2.16.254.1. Each part represents a group of 8 bits (octet) of the address. The following items "**IP 1**", "**IP 2**", "**IP 3**", "**IP 4**" allow you to set each part (number) of the address. After setting desired IP address, confirm the item "**Set Address**" to save this address.

**Net Mask\*** - **Network mask**. Use the menu item to set desired network mask. A network mask is a 32-bit mask used to divide an IP address into subnets and specify the networks available hosts.

The following items "**N. M.1**", "**N.M.2**", "**N.M.3**", "**N.M.4**" serve for setting of each part (number) of net mask. After setting desired network mask, confirm the item "**Set Net M.**" to save adjusted values.

\* LEDBeam 350 EP version only

### 5.2 Fixture information (Info)

**IP Addr\*** - **IP address**. Select this menu item to read the IP address of the fixture.

**MAC Addr\*** - **MAC address**. Select this menu item to read the MAC address of the fixture.

\* LEDBeam 350 EP version only

**POn Time** - **Power on time**. Select the menu to read the number of fixture operation hours.

**Total** - The item shows the total number of the operation hours since the ROBIN LEDBeam 350 has been fabricated.

**Reset** - The item shows the number of the operation hours that the ROBIN LEDBeam 350 has been powered on since the counter was last reset. In order to reset this counter to 0, press and hold both [NEXT] and [PREV] buttons and the [Enter] button at the same time.

**LOTi - LEDs on time.** Select the menu item to read the number of operation hours of individual LEDs (Red, Green, Blue, Amber).

**Air fil - Air filter.** Regular cleaning of the air filter in the fixture base is very important for the fixture's life and performance. Build-up of dust, dirt and fog fluid residues reduces the fixture's fan ability. The two items of this menu help you to keep cleaning period of the air filter.

**Alert P - Alert periode.** Cleaning schedule for the fixture depends on the operating environment.

It is therefore impossible to specify accurate cleaning interval. This item allows you to change the cleaning interval of the air filter. This "alert P" value is 300 hours and it is set as default. Inspect the fixture within its 300 hours of operation to see whether cleaning is necessary. If cleaning is required, clean air filter and change the value in this menu on acceptable level. Min. level of alert period is 10 hours, max. is 300 hours.

**R Ti - Remaining time.** The item allows you to read the time which remains to cleaning air filter. The time period is set in the menu mentioned above.

To reset this menu item press and hold both [NEXT] and [PREV] buttons and the [Enter] button at the same time.

**DMX In - DMX readout.** The menu is used to read DMX values of each channel received by the fixture.

**Hea Temp - Head Temperature.** The menu shows temperature on the LED module.

**Current** - a current temperature of the LED module.

**Highest** - a maximum temperature of the LED module since the fixture has been fabricated.

**High Res** - a maximum temperature of the LED module since the counter was last reset.

In order to reset this counter, press and hold both [NEXT] and [PREV] buttons and the [Enter] button at the same time.

**Sw Ver - Software versions.** Select this item to read the software version of the fixture modules.

**IC-1** - a pan/Tilt processor.

**IC-2** - a display processor.

**IC-3** - a LED control processor.

## 5.3 Personality (Pers)

**Ethernet\* - Ethernet settings.** Use the menu item to select and set desired operating mode.

**Ethernet mode** - use the menu to select a protocol.

**Artnet** - fixture will receive Artnet protocol.

**sACN** - fixture will receive sACN protocol.

**gMAI** - fixture will receive MANet I protocol.

**gMAII** - fixture will receive MANet 2 protocol.

**ArtNet** - the menu allows you to set parameter for ArtNet operation.

**Uni** - selection of ArtNet Universe (0-255).

**sACN** - the menu allows you to set parameter for sACN operation.

**Uni** - selection of sACN Universe (1-63999).

**MANet** - the menu allows you to set parameters for MANet operation.

**Uni** - selection of MANet Universe (1-63999).

**sID** - selection of the MANet I(II) session ID (1-32)

**IGMP r** - the menu allows you to set repeating time for Internet Group Management Protocol (Off, 1s-10s)

\* LEDBeam 350 EP version only

**DMX Pres - DMX preset.** Use the menu to select desired channel mode.

**Mode 1** - 22 control channels

**Mode 2** - 16 control channels

**Mode 3** - 24 control channels (default)

**Pan Rev** - Pan reverse. The item allows to invert pan movement.

**Tilt Rev** - Tilt reverse. The item allows to invert tilt movement.

**P/T Mode** - Pan and Tilt movement mode. Use this menu to set mode of the pan/tilt movement.

**Speed** - both Pan and tilt will move with the same speed as adjusted at the channel 5 "Pan/Tilt speed, Pan/Tilt time".

**Time** - the pan and tilt will move with different speeds and they will come at the same time to the end point of their tracks (pan and tilt use their optimal speeds).

Time of the pan/tilt movement (25.5 sec. max.) is set by the channel "Pan/Tilt speed, Pan/Tilt time".

**P/T Feed** - Pan and Tilt Feedback. The menu item allows to return the mowing head to the required pan/tilt position after changing the position by an external force if this option is set on.

Note. The Pan/Tilt Feedback should be permanent On, the option Off is not suitable for standard operation and the head of the fixture can be damaged!

**Pan range** - Pan movement range. The menu item allows you to select desired pan movement range:

**Standard** - pan movement range is 540°

**Reduced** - pan movement range is 450°

**Display** - Display adjusting. This menu allows you to adjust the display behaviour.

**Turn** - this function turns the display by 180°.

**On/Off T** - this function allows you to keep the display permanent on or turn it off two minutes after last pressing any button on the control panel.

**Contrast** - use this function to adjust contrast of the display (0-100%).

**Backlight** - use this function to adjust backlight of the display (0-100%).

**BLC DMC** - Blackout during movement correction. Set this option on if you wish to close light output during the time when the head goes to its correct position, which has been changed by an external force.

**BLC P/T** - Active blackout. The menu item allows to close light output while the pan/tilt DMX values are changing.

**C Mix M** - Colour mixing mode. This item allows you to switch into RGBA or CMY mode. In the CMY mode, the amber (8 bit)/amber (16 bit) channels are not active.

**White P** - White Point 8000K. If the function is on, the CTC channel allows to set desired white in range of 8000K-2700K (0 DMX=8000K, 255 DMX=2700K). Necessary condition is , that RGBW channels have to be full or set at the same DMX values, e.g. 150.

If this function is off, the range of whites is not uniform and may be different for each fixture.

**Mic Sens** - Microfon sensitivity. Enter the menu if you want to adjust the microphone sensitivity ( 0-max., 19-min.).

**Fans** - Fans setting. Use the menu to set behaviour of fixture fans.

**FansMode** - the menu allows you to select desired power of fans:

**High** - max. power of fans

**Auto** - auto-control mode

**Quiet** - If the options is selected, power of fans can be set in the menu "Noise L."

**BLC Fans** - the menu item allows you to stop all fans in the fixture (option "On") when its light output is closed (shutter in range of 0-31 DMX or dimmer in 0 DMX).

**Noise L.** - the menu item allows you to set speed of fans. At low speed of fans the light output may be reduced.

**Dimmer C** - Dimmer curve. Use the menu to select desired dimmer curve.

**Linear** - a linear curve.

**Square** - a square law curve.

**LED Freq** - LEDs frequency setup. The function allows you to set the PWM (Pulse Width Modulation) output

frequency of LEDs to Standard or High. You can select from the following values:

300 Hz  
600 Hz  
1200 Hz  
2400 Hz  
High

**LED Fadj - LEDs frequency fine adjustment.** The function allows you to change the selected PWM output frequency of LEDs in 6 levels up and down around the selected frequency in the menu "LED Freq".

-06...-01 - Frequency levels 1-6 under selected frequency.

00 - Selected frequency

01...06 - Frequency levels 1-6 above selected frequency.

**Temp Uni - Temperature unit.** Use the menu item to change temperature unit from °C to °F.

**I Ef Pos - Init effect positions.** Use the menu to set all effects to the desired positions at which they will stay after switching the fixture on without DMX signal connected.

**Defaults** - the menu item allows to set all fixture parameters to the default (factory) values.

## 5.4 Manual Control (Manual)

Use the menu to control all fixture channels by means of control buttons.

## 5.5 Test program (Test Prg)

Use this menu to to run a special demo-test sequences without an external controller, which will show you some possibilities of using ROBIN LEDBeam 350.

**Static - Static mode.** This mode is suitable for projections on the wall, ceiling or ground without any head movement.

**Dynamic - Dynamic mode.** This mode uses all ROBIN LEDBeam 350 functions including pan/tilt movement and therefore is good for a complete introduction of the fixture.

## 5.6 Stand-alone (St Alone)

**Music T - Music trigger.** Select this function to enable the sound control of the running program via the built-in microphone.

**Auto Run - Presetting playback.** This function allows you to select the program which will be played in the stand-alone mode after switching the fixture on. Selected program will be played continuously in a loop.

**Off** - the option disables „Auto Run” function.

**Test** - The option will start built-in test program.

**Prog 1** - the option will start user-created program 1

**Prog 2** - the option will start user-created program 2

**Prog 3** - the option will start user-created program 3

**Pr Play - Playing program.** Select this menu to run a user-created program in a loop.

**Test Prg** - the option runs built-in test program.

**Prog 1** - the option runs user-created program 1

**Prog 2** - the option runs user-created program 2

**Prog 3** - the option runs user-created program 3

Select the program you wish and press [ENTER]. The selected program starts running. By Pressing [ENTER] again, program pauses running.

**Pr Edit - Editing program.** Select this menu to edit or create the program. The ROBIN LEDBeam 350 has one built-in program and one user-editable program up to 40 steps. Each program step has a step time - during which effects last in the current step and a fade time- during which effects move to new positions.

To edit program:

**Procedure:**

1. Press [NEXT] or [PREV] to select the menu "Edit" and press [ENTER].

2. Press [NEXT] or [PREV] to select the desired program step and press [ENTER] button.

3. Press [NEXT] or [PREV] to select the desired item and press [ENTER] button. Now you can edit by [NEXT] or [PREV] buttons the DMX value (0-255) for selected item:

Prg End.	a total number of the program steps (value 1-40). This value you should be set before starting of programming (e.g. if you want to create program with the 10 steps, set Prg End=10).
PAn	a coarse pan movement
PAn F	a fine pan movement
Tilt	a coarse tilt movement
Tilt F	a fine tilt movement
P/T Sp	a pan/tilt speed
Powr	power/special functions
Virt C	a virtual colour wheel
Red	a red colour coarse
Red F	a red colour fine
Green	a green colour coarse
Green F	a green colour fine
Blue	a blue colour coarse
Blue F	a blue colour fine
White	a white colour
White F F	a white colour fine
CTC	a colour temperature correction
C Mix C	a colour mix control
Zoom	a zoom function
Zoom F	a zoom function fine
Stro	a strobe/shutter function
Dimm	a dimmer function coarse
Dim F	a dimmer function fine
F.Tim	a fade time (0-25.5 sec)
S.Tim	a step time (0-25.5 sec)
COPY	copying the current prog. step to the next prog. step

4. Press [ENTER] button to confirm adjusted value .

5. Press [ESCAPE] button, select next prog. step, press [ENTER] button and repeat steps 3 - 5).

## 5.7 Reset

This option enables the ROBIN LEDBeam 350 to index all effects and return to their standard positions.

## 5.8 Special functions (Special)

**RDM Low** - this menu item shows the first part of the RDM identification code.

**RDM High** - this menu item shows the second part of the RDM identification code.

**Wireless** - **Wireless DMX information**. The menu allows to read some information about Wireless DMX operation

**Stat** - **Wireless status**. Use the menu to read wireless DMX status.

**Unlink** - use this item to unlink fixture from wireless DMX.

**Adjust** - **Adjustment**. The menu allows the fine adjustment of effects.

**DMX Val**- **DMX values**. Use the menu to set DMX values of fixture's channels.

**Calib** - calibration of white colour.

**Cal Mech** - use this menu to calibrate pan/tilt/zoom position.

**Cal Col** - the menu serves for calibration of white colours in the factory.  
User should not change settings in this menu.

*Calibration of the pan/tilt/zoom via the control board*

1. Disconnect DMX controller from the fixture and enter the "Cal Mech" menu.
2. Use the [PREV] and [NEXT] to find "Pan C" and press [ENTER].

3. Set desired value and save it by pressing [ENTER].
4. Repeat steps 2 and 3 for "Tilt C" and "Zoom C".
5. After calibrating all effects, find item "Store" and press [ENTER]. to save all adjusted values and reset the fixture.

Calibration protocol

<b>Effect</b>	<b>Mode 1</b>	<b>Mode 2</b>	<b>Mode 3</b>
Pan-fine adjustment	channel 23	channel 17	channel 25
Tilt - fine adjustment	channel 24	channel 18	channel 26
Zoom -fine adjustment	channel 25	channel 19	channel 27

**Cal Load** - Loads default (factory) calibration.

**Sw Upd - Software update.** The menu item allows you to update software in the fixture via either serial or USB port of PC.

The following items are required in order to update software:

- PC running Windows or Linux or macOS
- DSU file
- Flash cable RS232/DMX, P/N13050624 (if you want to use a serial port of PC)
- Robe Universal Interface or Robe Universal interface WTX (if you want to use an USB port of PC)

After the software updating the fixture will be set to default (factory) values.

To update software in the fixture:

1. DSU file is available from Robe web site at [WWW.robe.cz](http://WWW.robe.cz).  
 File with extension zip is intended for Windows (used and tested from XP to W10 on 32/64bit systems).  
 File with extension tbz is intended for Linux (used and tested on Debian and Ubuntu 32/64bit).  
 File with extension dmg is intended for macOS (used and tested on OSX up to Sierra) XQuartz required, install it from <https://www.xquartz.org/>  
 Save the download file to a folder on your computer.  
 In case that you use windows, extract files in the zip file (e.g. DSU\_RobinLedBeam350\_18041738.zip)
2. Disconnect the fixture from DMX controller.
3. If you use the flash cable RS232/DMX, connect a serial port of your computer with DMX input of the fixture by means of the cable.  
 If you use the Robe Universal Interface, connect a USB port of your computer with the Robe Universal Interface by means of the USB cable and DMX input of the fixture with the DMX output of the Robe Universal Interface via a DMX cable.
4. Switch the fixture to the update mode (Special --> SW Upd).  
 Note: If you do not want to continue in the software update, you have to switch off and on the fixture to escape from the updating mode.  
 We recommend to cancel all running programs on your computer before starting the software update.
5. Double-click the software uploader file (e.g. DSU\_RobinLedBeam350\_18041738.exe) in the extracted files. The Software Uploader program will start running.

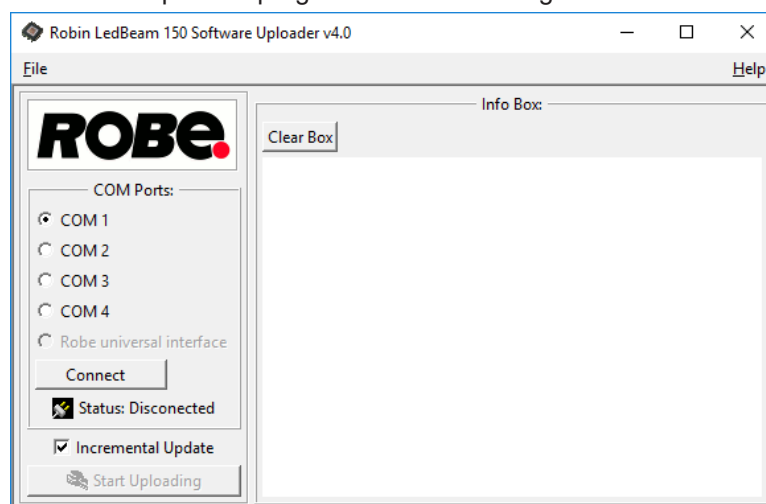

6. Select correct "COM " number if you use a Flash cable RS232/DMX or select "Robe Universal Interface 1 " if you use the Robe Universal Interface/Robe Universal Interface WTX and then click on the "Connect" button.
7. If the connection is OK, click the "Start Uploading" button to start software uploading. It will take several minutes to perform software update.  
 If the option "Incremental Update" is not checked, all processors will be updated (including processors with



the same software version).

If you wish to update only processors with new version of software, check the “Incremental Update box”.

Avoid interrupting the process. Update status is being displayed in the "Info Box" window.

When the update is finished, the line with the text “Fixture is successfully updated” will appear in this window.

In case upload process is interrupted (e.g. power loss), the fixture stays in “Updating mode” and you will have to repeat the software update again.

Another way, how to update software in the fixtures (especially large installation of fixtures) is to use the ROBE Uploader. It is a software for automatized software update of Robe fixtures. It takes advantage of RDM support).

For more information please see <https://www.robe.cz/robe-uploader/>.

## 6. RDM

This fixture supports RDM operation. RDM (Remote Device Management) is a bi-directional communications protocol for use in DMX512 control systems, it is the new open standard for DMX512 device configuration and status monitoring.

The RDM protocol allows data packets to be inserted into a DMX512 data stream without adversely affecting existing non-RDM equipment. By using a special „Start Code,“ and by complying with the timing specifications for DMX512, the RDM protocol allows a console or dedicated RDM controller to send commands to and receive messages from specific moving lights.

RDM allows explicit commands to be sent to a device and responses to be received from it.

The list of commands for ROBIN LEDBeam 350 is the following.

Parameter ID	Discovery command	SET command	GET command
DISC_UNIQUE_BRANCH	*		
DISC_MUTE	*		
DISC_UN_MUTE	*		
DEVICE_INFO			*
SUPPORTED_PARAMETERS			*
SOFTWARE_VERSION_LABEL			*
DMX_START_ADDRESS		*	*
IDENTIFY_DEVICE		*	*
DEVICE_MODEL_DESCRIPTION			*
MANUFACTURER_LABEL			*
DEVICE_LABEL		*	*
SENSOR_DEFINITION			*
SENSOR_VALUE			*
DISPLAY_INVERT		*	*
DISPLAY_LEVEL		*	*
PAN_INVERT		*	*
TILT_INVERT		*	*
DEVICE_RESET		*	
DMX_PERSONALITY		*	*
DMX_PERSONALITY_DESCRIPTION			*
STATUS_MESSAGES			*
STATUS_ID_DESCRIPTION			*
DEVICE_HOURS			*
PARAMETER_DESCRIPTION			*
ROBE_DMX_INPUT		*	*
ROBE_WIRELESS_UNLINK		*	

RDM model ID for the Robin LEDBeam 350 is 0x0113.

## 7. Error and information messages

### **Tilt Err**

This message will appear after reset of the fixture if the head's indexing circuit malfunctions (sensor failed) or the stepping motor or its driving PCB is defective. The head is not located in the default tilt position after fixture reset.

### **Pan Err**

This message will appear after reset of the fixture if the head's indexing circuit malfunctions (sensor failed) or the stepping motor or its driving PCB is defective. The head is not located in the default pan position after fixture reset.

### **Zoom Err**

This message will appear after reset of the fixture if the zoom module is not located in the default position. Cause of the message can be some defective zoom stepping motor.

### **Red Shrt**

The message informs you that short circuit has occurred in the red LEDs circuit on the LEDs PCB.

### **Green Shrt**

The message informs you that short circuit has occurred in the green LEDs circuit on the LEDs PCB.

### **Blue Shrt**

The message informs you that short circuit has occurred in the blue LEDs circuit on the LEDs PCB.

### **White Shrt**

The message informs you that short circuit has occurred in the white LEDs circuit on the LEDs PCB.

### **Red Unp**

The message informs you that red LEDs circuit has been interrupted on the LEDs PCB.

### **Green Unp**

The message informs you that green LEDs circuit has been interrupted on the LEDs PCB.

### **Blue Unp**

The message informs you that blue LEDs circuit has been interrupted on the LEDs PCB.

### **White Unp**

The message informs you that white LEDs circuit has been interrupted on the LEDs PCB.

### **Clea Air F**

The message informs you that the item "R Ti" is at 0 value (in the menu "Air fil"). Clean air filter in the fixture base reset this counter.



## 8. Technical Specifications

### Electrical

Power supply: electronic auto-ranging  
Input voltage range: 100-240V, 50-60Hz  
Fuse: T 6.3A/250V ~  
Max. power consumption: 450W (power factor: 0.96)  
Mains input: - max. 16A (US 13A)

### Source

Light source type: 12 RGBW multichips  
LED life expectancy: min. 50.000 hours  
Typical lumen maintenance: : L70/B50 @ 50.000 hours

### Optical System

Robe's proprietary optical design  
Zoom range: 3.8° - 60° (LedBeam 350)  
Zoom range: 3.8° - 60° (LedBeam 350 FW)

### Virtual colour wheel

66 pre-programmed colours  
Rainbow effect with in both directions with variable speed

### CTO

Variable CTO 2700K-8000K  
Pre-programmed whites 2.700K, 3.200K, 4.200K, 5.600K and 8.000K  
Halogen lamp effect at whites 2700K-4200K

### Strobe

Strobe effect with variable speed (0.3 - 20Hz)  
Random strobe pulse-effect with variable speed  
Opening/closing pulse effect with variable speed

### Dimmer

Smooth dimmer from 0 - 100 %

### Pan/Tilt

Max. pan movement range: 540° or 450°(switchable)  
Max. tilt movement range: 228°  
16 bit movement resolution  
Automatic Pan/Tilt position correction  
Remotely controllable speed of pan/tilt movement for easy programming

### Control

Two-row LCD display & 4 control buttons  
Readout fixture usage, receiving DMX values, temperatures, etc  
Built-in analyzer for easy fault finding, error messages  
Built-in demo sequences  
Silent fans cooling,  
Stand-alone operation  
3 user editable programs, each up to 40 steps  
Supported protocols: USITT DMX 512, RDM,  
Support of RDM (Remote Device Management)  
3 DMX modes (22, 16, 24 control channels)

### External Wireless DMX/RDM module (optional)

Compliance with USITT DMX-512 (1986 & 1990) and 512-A  
Full DMX fidelity and frame integrity  
Auto sensing of DMX frame rate and frame size

<5ms DMX latency  
Operational frequency range of 2402-2480 MHz  
Producer: LumenRadio

**Max. number of fixtures in Ethernet IN/Out line (EP version only)**  
8

**Connection**

DMX data in/out: Locking 5-pin XLR  
Ethernet In/Out: 2 x RJ 45 (Robin LEDBeam 350 EP only)  
Power IN: Neutrik powerCON TRUE1  
Power OUT: Neutrik powerCON TRUE1

**Rigging**

Mounting points: 2 pairs of 1/4-turn locks  
Mounting horizontally or vertically via Omega bracket

**Temperatures**

Maximum ambient temperature : 45° C  
Maximum housing temperature : 70° C

**Distances**

Min. distance from flammable surfaces: 0.4 m  
Min. distance of illuminated objects: 1.5 m

**Total heat dissipation**

1153 BTU/h (calculated)

**Weight:**

9.85 kg

**Dimensions (mm)**

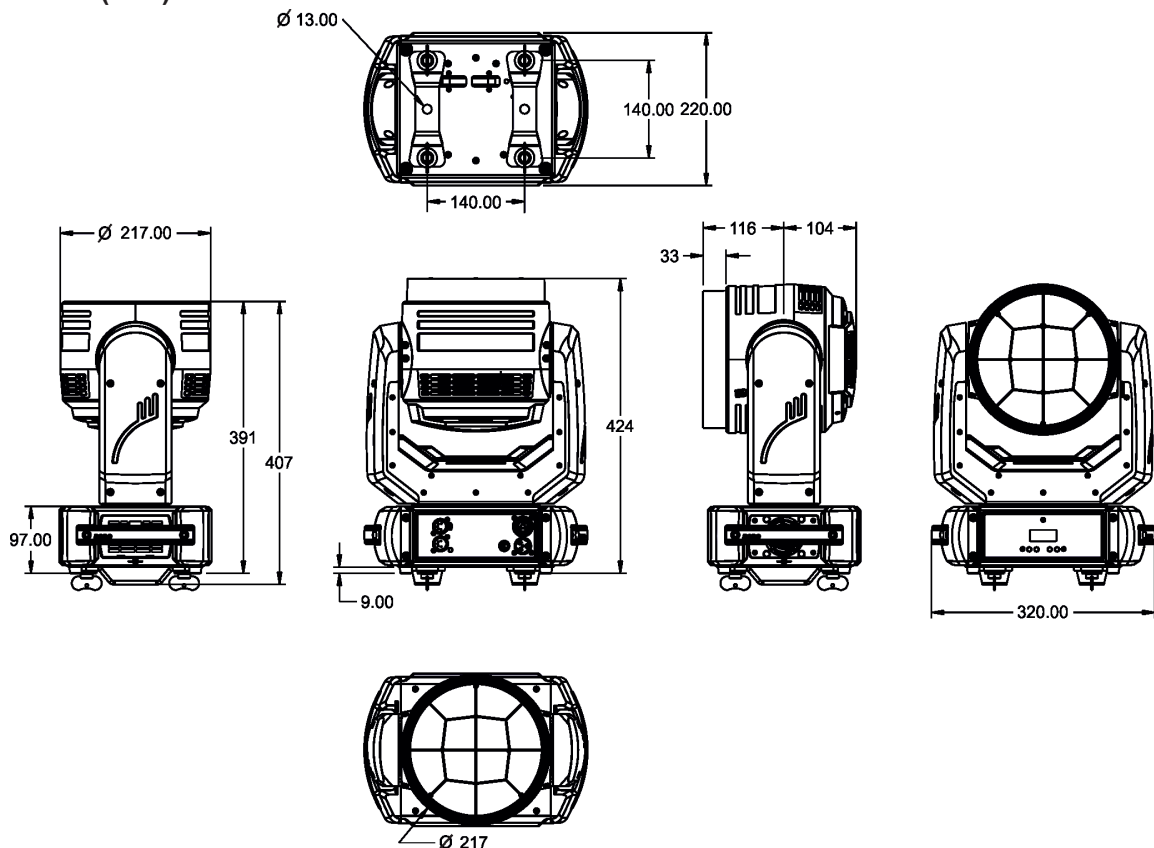

**Accessories**

1 x Omega adapter CL-regular 2 pcs in box (P/N 10980033)

## Optional accessories

- (P/N 10980559) Diffusion Filter 2° for LEDBeam 350
- (P/N 10980560) EggCrate for LEDBeam 350
- (P/N 10980127) ROBE Wireless CRMX Dongle
- (P/N 1305 2405) Mains Cable PowerCon In TRUE1/Schuko, 2m, indoor
- (P/N 1305 2406) Mains Cable PowerCon In TRUE1/US, 2m, indoor
- (P/N 1305 2407) Mains Cable PowerCon In TRUE1/open ended, 2m, indoor
- (P/N 13052445) Mains Cable PowerCon In TRUE1/CEE 16A, 2m, indoor
- (P/N 1305 2439) Daisy Chain PowerCon TRUE1 In/Out, EU, 2m, indoor
- (P/N 1305 2440) Daisy Chain PowerCon TRUE1 In/Out, US, 2m, indoor
- (P/N 13052444) Daisy Chain PowerCon TRUE1 In/Out, EU, 5m, indoor
- (P/N 17030386) Doughty Trigger Clamp
- (P/N 99011963) Safety wire 35 kg

## 9. Maintenance and cleaning

It is absolutely essential that the fixture is kept clean and that dust, dirt and smoke-fluid residues must not build up on or within the fixture. Otherwise, the fixture's light output will be significantly reduced. Regular cleaning will not only ensure the maximum light output, but will also allow the fixture to function reliably throughout its life. A soft lint-free cloth moistened with any weak detergent solution is recommended for cleaning fixture's covers, under no circumstances should alcohol or solvents be used!

***DANGER !***  
***Disconnect from the mains before starting any  
maintenance and cleaning work***

The interior of the fixture should be cleaned at least annually using a vacuum cleaner or compressed air. The cooling fans should be cleaned at least twice a year.

**Important! Never use alcohols (ethanol, methanol, isopropyl alcohol), acetone and another aggressive solvents for cleaning the front lens array.**

Recommended steps for cleaning the LED lens array:

1. Use low-pressure compressed air to remove coarse dust from lenses.
2. Use distilled water with weak detergent solution and lint-free small cloth for further cleaning of lenses.
3. Use an antistatic, alcohol-free screen cleaner (we recommend the Lyreco Screen Cleaner) and polish lenses until they are dry.
4. Check the lenses are dry before reapplying power.

Note: potential foggy front lens array does not influence function of the fixture and does not subject to complaint.

Periodically clean the air filter placed in the fixture base. This air filter is placed under a grille, which is fastened by means of two magnets.

Use a vacuum cleaner, compressed air or you can wash them and put back dry.

After replacing the air filter, set the remaining time counter in the menu "Fixture Information" (Info--->Air fil. --->R. Ti)

More complicated maintenance and service operations are only to be carried out by authorized distributors.

### 9.1 Replacing fuse

1. Replace the fuse by a fuse of the same type and rating only.

**Before replacing the fuse, unplug mains lead!**

1. Remove the fuse holder on the rear panel of the base with a fitting screwdriver from the housing (anti-clockwise).
2. Remove the old fuse from the fuse holder.
3. Install the new fuse in the fuse holder (only the same type and rating).
4. Replace the fuse holder in the housing and fix it.

# 10. Photometric diagrams

## Robin LedBeam 350

### Min. Zoom

Total Output: 2640 lumens

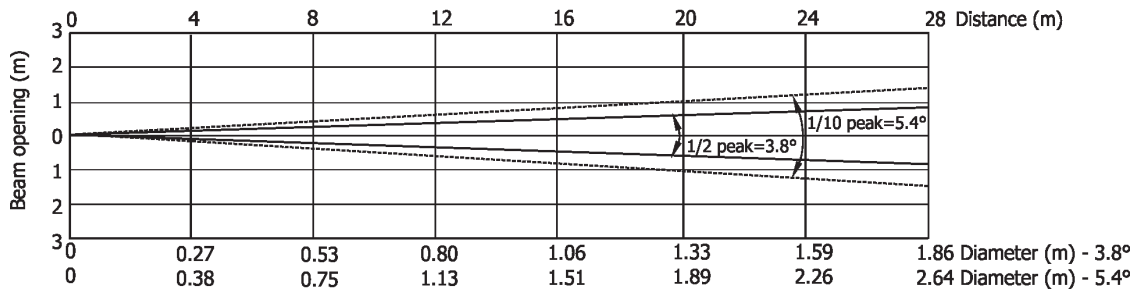

Distance (m)	4	5	8	12	16	20	24	28	
Red	10375/964	6640/617	2594/241	1152/107	648/60	415/39	288/27	211/20	Intensity (center) Lux/footcandles
Green	18125/1684	11600/1078	4531/421	2013/187	1132/105	720/67	503/47	370/34	
Blue	5328/495	3410/317	1332/124	592/55	333/31	213/20	148/14	109/10	
White	22188/2061	14200/1319	5547/515	2465/229	1387/129	887/83	616/57	453/42	
R+G+B+W	44063/4094	28200/2620	11015/1023	4895/455	2753/256	1762/164	1224/114	899/84	

### Illuminance distribution

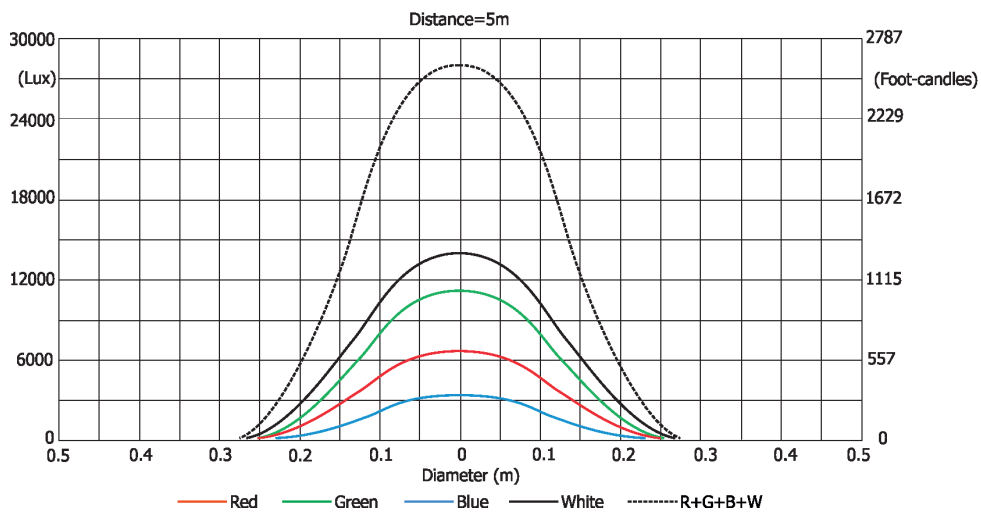

# Robin LedBeam 350

## Max. Zoom

Total Output: 6574 lumens

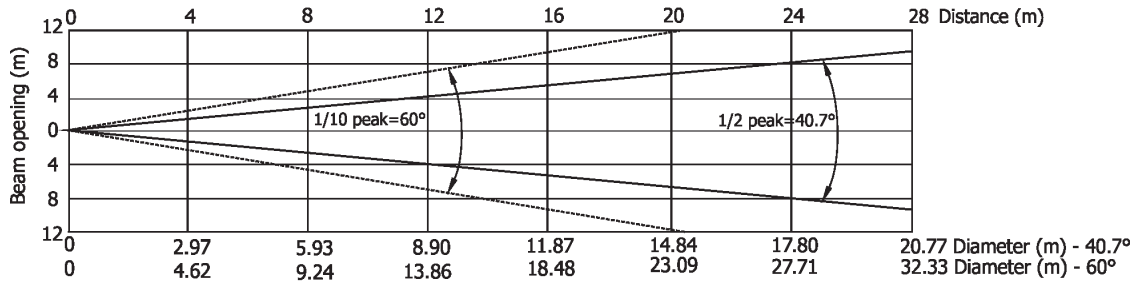

Distance (m)	4	5	8	12	16	20	24	28	
Red	207/19	133/12	52/5	23/2.1	13/1.2	8/0.8	6/0.5	4/0.4	Intensity (center) Lux/Footcandles
Green	348/32	223/21	87/8	39/3.6	22/2	14/1.3	10/0.9	7/0.7	
Blue	102/9	65/6	25/2.4	11/1	6/0.6	4/0.4	3/0.3	2/0.2	
White	410/38	262/24	102/10	45/4	26/2.4	16/1.5	11/1.1	8/0.8	
R+G+B+W	844/78	540/50	211/20	94/9	53/4.9	34/3.1	23/2.2	17/1.6	

## Illuminance distribution

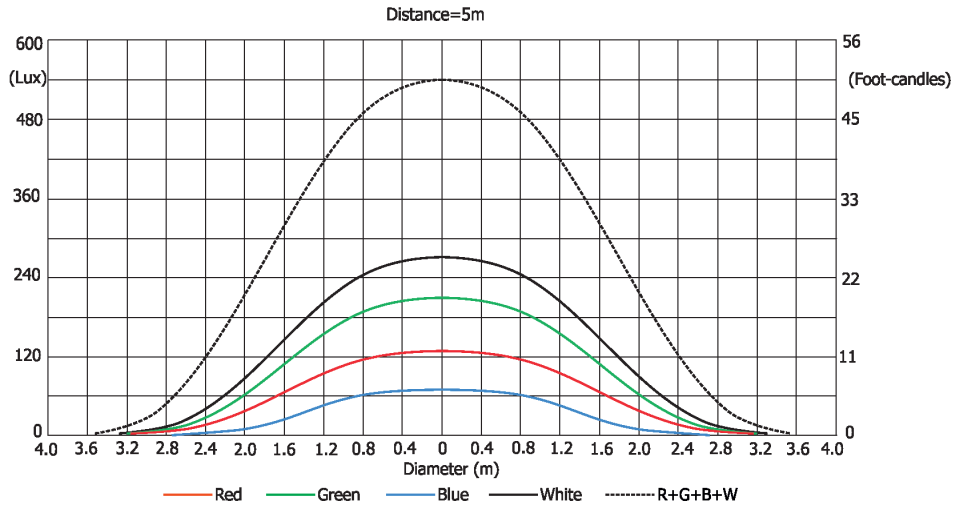

# Robin LedBeam 350 FW

## Min. Zoom

Total Output: 2350 lumens

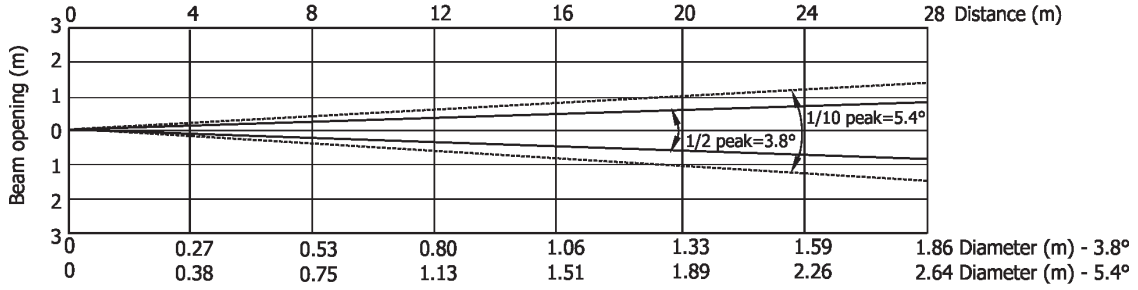

Distance (m)	4	5	8	12	16	20	24	28	
Red	5375/499	3440/320	1344/125	597/56	336/31	215/20	150/14	110/10	Intensity (center) Lux/Footcandles
Green	10859/1009	6950/646	2715/252	1206/112	679/63	434/40	302/28	221/21	
Blue	2297/1470	1470/137	574/53	255/24	144/13	92/9	64/6	47/4.4	
White	14062/1306	9000/836	3515/327	1563/145	879/82	563/52	390/36	287/27	
R+G+B+W	31250/2903	20000/1858	7813/726	3472/323	1953/182	1250/116	868/81	638/59	

## Illuminance distribution

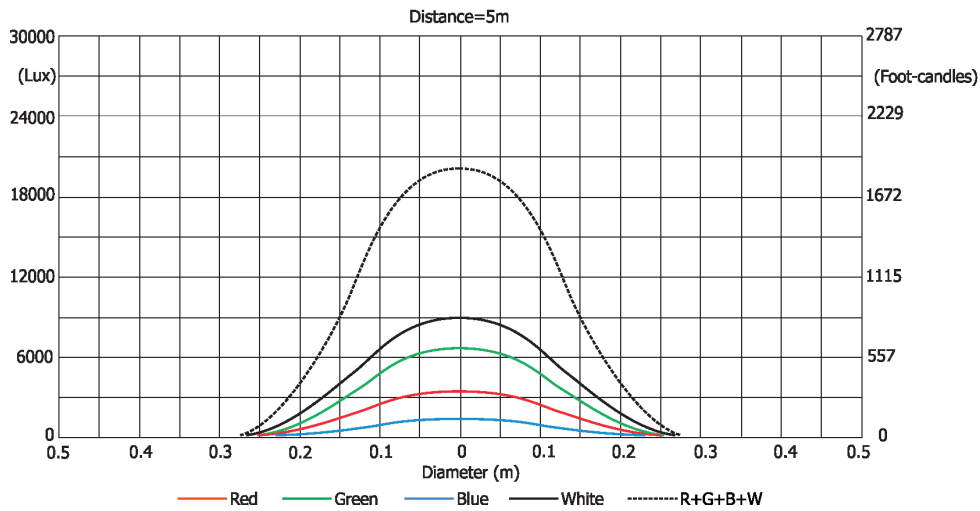

# Robin LedBeam 350 FW

## Max. Zoom

Total Output: 5875 lumens

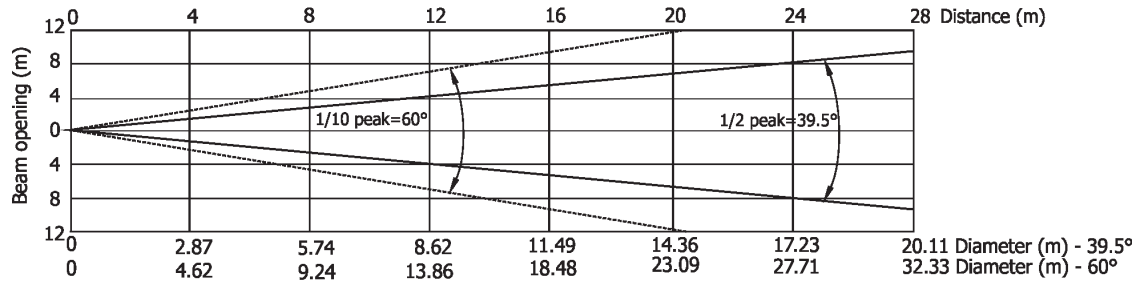

Distance (m)	4	5	8	12	16	20	24	28	
Red	130/12	83/8	32/3	14/1.3	8/0.8	5/0.5	4/0.3	3/0.2	Intensity (center) Lux/Footcandles
Green	268/25	172/16	67/6	30/2.8	17/1.6	11/1.0	8/0.7	6/0.5	
Blue	59/6	38/3.5	15/1.4	7/0.6	4/0.3	2/0.2	1.6/0.2	1.2/0.1	
White	342/32	219/20	86/8	38/3.5	21/2	14/1.3	10/0.9	7/0.6	
R+G+B+W	800/74	512/48	200/19	89/8	50/4.6	32/3.0	22/2.1	16/1.5	

## Illuminance distribution

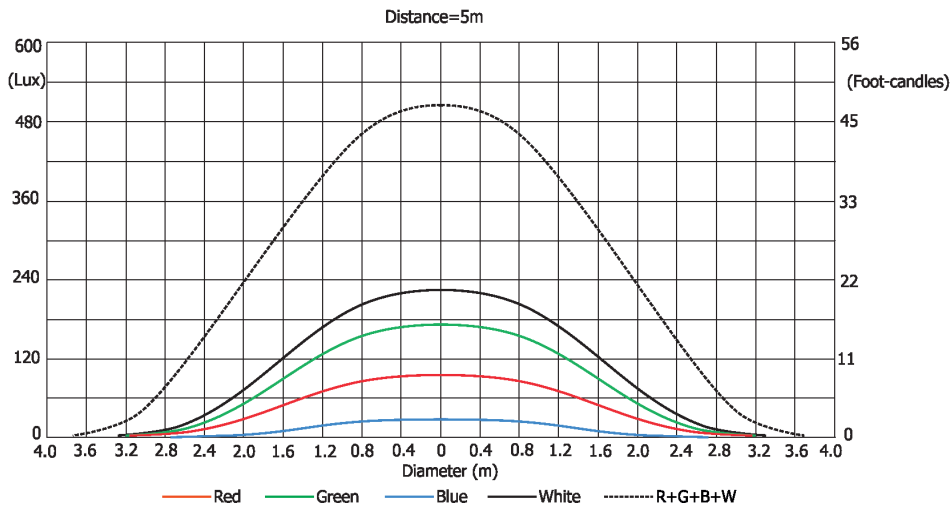

## 11. ChangeLog

This section summarizes changes in the user manual.

Version of the manual	Date of issue	Description of changes
1.1	04/01/2021	DMX chart v. 1.2
1.2	27/01/2021	Menu item P movement range added
1.3	11/02/2021	Photometric changed
1.4	03/03/2021	Photometric diagrams for LB 350 FW added
1.5	17/03/2021	DMX chart v. 1.3
1.6	26/05/2021	Eggcrate and diffusion filter installation added
1.7	17/06/2021	Menu Calibration changed
1.8	31/07/2021	Eggcrate installation changed
1.9	12/08/2021	EP version added
2.0	03/09/2021	DMX chart v. 1.4
2.1	24/01/2022	Ethernet connection for EP version added
2.2	09/02/2022	DMX chart v. 1.5
2.3	01/04/2022	Safety instructions changed
2.4	13/04/2022	Diffusion filter installation changed
2.5	04/10/2022	Colours calibration chanded
2.6	01/12/2022	LED Life expectancy changed



DMX protocol

**Robin LedBeam 350/Robin LedBeam 350FW - DMX protocol**

Version: 1.5 **Mode 1**-Standard 16-bit, **Mode 2** -Reduced 8-bit, **Mode 3** - Cpulse mode

Mode/channel			DMX Value	Function	Type of control
1	2	3			
1	1	1		<b>Pan (8 bit)</b>	
			0 - 255	Pan movement by 540° or 450° (128=default)	proportional
2	2	2		<b>Pan Fine (16 bit)</b>	
			0 - 255	Fine control of pan movement (0=default)	proportional
3	3	3		<b>Tilt (8 bit)</b>	
			0 - 255	Tilt movement by 228° (128=default)	proportional
4	4	4		<b>Tilt fine (16 bit)</b>	
			0 - 255	Fine control of tilt movement (0=default)	proportional
5	5	5		<b>Pan/Tilt speed , Pan/Tilt time</b>	
			0	Standard mode (0=default)	step
			1	Max. Speed Mode	step
				<b>Pan/Tilt speed mode</b>	
			2 - 255	Speed from max. to min.	proportional
				<b>Pan/Tilt time mode</b>	
			2 - 255	Time from 0.2 sec. to 25.5 sec.	proportional
6	6	6		<b>Power/Special functions</b>	
			0 -19	Reserved (0=default)	
				<i>To activate following functions, stop in DMX value for at least 3 s and shutter must be closed at least 3 sec. („Shutter,Strobe” channel 20/15/22 must be at range: 0-31 DMX). Corresponding menu items are temporarily overridden.</i>	
			20-24	Display On	step
			25-29	Display Off	step
			30-34	RGBW colour mixing mode	step
			35-39	CMY colour mixing mode	step
			40-44	Pan/Tilt speed mode	step
			45 - 49	Pan/Tilt time mode	step
			50 -54	Blackout while pan/tilt moving	step
			55 -59	Disabled blackout while pan/tilt moving	step
			60 - 64	Dimmer curve - square law	step
			65 - 69	Dimmer curve - linear	step
			70 - 74	Fans mode: Auto	step
			75 - 79	Fans mode: High	step
			80-84	White point 8000K ON	step
			85-89	White point 8000K OFF	step
			90-94	Reserved	
			95-99	Pan 540°	step
			100-104	Pan 450°	step
			105-109	Quiet mode: Fans On at blackout	step
			110-114	Quiet mode: Fans Off at blackout	step
			115 -129	Reserved	
				<i>To activate following functions, stop in DMX value for at least 3 seconds. Corresponding menu items are temporarily overridden.</i>	
			130 - 139	Reserved	
			140 - 149	Pan/Tilt reset	step
			150 - 159	Zoom reset	step

DMX protocol

Mode/channel			DMX Value	Function	Type of control
1	2	3			
			160 - 169	Reserved <i>Tungsten effect simulation for whites 2700K-4200K</i>	step
			170-171	Tungsten effect simulation (750W) On	step
			172-173	Tungsten effect simulation (1000W) On	step
			174-175	Tungsten effect simulation (1200W) On	step
			176-177	Tungsten effect simulation (2000W) On	step
			178-179	Tungsten effect simulation (2500W) On	step
			180-181	Tungsten effect simulation Off	step
			182-199	Reserved	
			200 - 209	Total fixture reset	step
			210 - 218	Reserved	
				The following RoboSpot related commands are only applicable when the RoboSpot is connected:	
			219 - 220	RoboSpot enabled	step
			221 - 222	RoboSpot disabled - except handle faders and pan/tilt	step
			223 - 224	RoboSpot fully disabled	step
			225-239	Reserved	
			240	Disabled "Quiet mode"	step
			241 - 255	Quiet mode - fan noise control from min. to max.	proportional
*	*	7		<b>LED frequency selection</b> Factory display menu setting: 600Hz <i>Select PWM output frequency of LEDs (DMX mode 3 only). Selected PWM frequency can be fine adjusted in 127 steps up/down around selected PWM frequency on the channel below. Corresponding menu item (Frequency Setup) is temporarily overridden.</i>	
			0-4	PWM frequency from Display menu (fixture utilizes PWM frequency set in the display menu item Frequency Setup).	step
			5-9	300 Hz	step
			10-14	600 Hz (10=default)	step
			15-19	1200 Hz	step
			20-24	2400 Hz	step
			25-29	High	step
			30-255	Reserved (fixture utilizes PWM frequency set in the display menu item Frequency Setup).	
*	*	8		<b>LED frequency fine adjusting</b> Factory display menu setting: 600Hz <i>Select desired PWM output frequency of LEDs on the channel above (DMX mode 3 only).</i>	
			0-1	Selected LED Frequency	step
			2	LED Frequency (step -126)	step
			3	LED Frequency (step -125)	step
			4	LED Frequency (step -124)	step
			:		
			125	LED Frequency (step -3)	step
			126	LED Frequency (step -2)	step
			127	LED Frequency (step -1)	step
			128	Selected LED Frequency (128=default)	step
			129	LED Frequency (step +1)	step
			130	LED Frequency (step +2)	step
			131	LED Frequency (step +3)	step
			:		

## DMX protocol

Mode/channel			DMX Value	Function	Type of control
1	2	3			
			252	LED Frequency (step +124)	step
			253	LED Frequency (step +125)	step
			254	LED Frequency (step +126)	step
			255	Selected LED Frequency	step
<b>7</b>	<b>7</b>	<b>9</b>		<b>Virtual colour wheel</b>	
			0	No function (0=default)	step
			1-2	Filter 4 (Medium Bastard Amber)	step
			3-4	Filter 25 (Sunset Red)	step
			5-6	Filter 19 (Fire)	step
			7-8	Filter 26 (Bright Red)	step
			9-10	Filter 58 (Lavender)	step
			11-12	Filter 68 (Sky Blue)	step
			13-14	Filter 36 (Medium Pink)	step
			15-16	Filter 89 (Moss Green)	step
			17-18	Filter 88 (Lime Green)	step
			19-20	Filter 90 (Dark Yellow Green)	step
			21-22	Filter 49 (Medium Purple)	step
			23-24	Filter 52 (Light Lavender)	step
			25-26	Filter 102 (Light Amber)	step
			27-28	Filter 103 (Straw)	step
			29-30	Filter 140 (Summer Blue)	step
			31-32	Filter 124 (Dark Green)	step
			33-34	Filter 106 (Primary Red)	step
			35-36	Filter 111 (Dark Pink)	step
			37-38	Filter 115 (Peacock Blue)	step
			39-40	Filter 126 (Mauve)	step
			41-42	Filter 117 (Steel Blue)	step
			43-44	Filter 118 (Light Blue)	step
			45-46	Filter 122 (Fern Green)	step
			47-48	Filter 182 (Light Red)	step
			49-50	Filter 121 (Filter Green)	step
			51-52	Filter 128 (Bright Pink)	step
			53-54	Filter 131 (Marine Blue)	step
			55-56	Filter 132 (Medium Blue)	step
			57-58	Filter 134 (Golden Amber)	step
			59-60	Filter 135 (Deep Golden Amber)	step
			61-62	Filter 136 (Pale Lavender)	step
			63-64	Filter 137 (Special Lavender)	step
			65-66	Filter 138 (Pale Green)	step
			67-68	Filter 798 (Chrysalis Pink)	step
			69-70	Filter 141 (Bright Blue)	step
			71-72	Filter 147 (Apricot)	step
			73-74	Filter 148 (Bright Rose)	step
			75-76	Filter 152 (Pale Gold)	step
			77-78	Filter 154 (Pale Rose)	step
			79-80	Filter 157 (Pink)	step
			81-82	Filter 143 (Pale Navy Blue)	step
			83-84	Filter 162 (Bastard Amber)	step
			85-86	Filter 164 (Flame Red)	step

DMX protocol

Mode/channel			DMX Value	Function	Type of control
1	2	3			
			87-88	Filter 165 (Daylight Blue)	step
			89-90	Filter 169 (Lilac Tint)	step
			91-92	Filter 170 (Deep Lavender)	step
			93-94	Filter 172 (Lagoon Blue)	step
			95-96	Filter 194 (Surprise Pink)	step
			97-98	Filter 180 (Dark Lavender)	step
			99-100	Filter 181 (Congo Blue)	step
			101-102	Filter 197 (Alice Blue)	step
			103-104	Filter 201 (Full C.T. Blue)	step
			105-106	Filter 202 (Half C.T. Blue)	step
			107-108	Filter 203 (Quarter C.T. Blue)	step
			109-110	Filter 204 (Full C.T. Orange)	step
			111-112	Filter 219 (Fluorescent Green)	step
			113-114	Filter 206 (Quarter C.T. Orange)	step
			115-116	Filter 247 (Filter Minus Green)	step
			117-118	Filter 248 (Half Minus Green)	step
			119-120	Filter 281 (Three Quarter C.T. Blue)	step
			121-122	Filter 285 (Three Quarter C.T. Orange)	step
			123-124	Filter 352 (Glacier Blue)	step
			125-126	Filter 353 (Lighter Blue)	step
			127-128	Filter 507 (Madge)	step
			129-130	Filter 778 (Millennium Gold)	step
			131-132	Filter 793 (Vanity Fair)	step
			133-235	Raw DMX	proportional
			236-245	Rainbow effect (with fade time) from slow-> fast	proportional
			246-255	Rainbow effect (without fade time) from slow-> fast	proportional
<b>8</b>	<b>8</b>	<b>10</b>		<b>Red/Cyan (8 bit)*</b>	
			0 - 255	Colour saturation control - coarse 0-100% (255=default)	proportional
<b>9</b>	<b>*</b>	<b>11</b>		<b>Red/Cyan (16bit)*</b>	
			0 - 255	Colour saturation control - fine (255=default)	proportional
<b>10</b>	<b>9</b>	<b>12</b>		<b>Green/Magenta (8 bit) *</b>	
			0 - 255	Colour saturation control - coarse 0-100% (255=default)	proportional
<b>11</b>	<b>*</b>	<b>13</b>		<b>Green/Magenta (16bit) *</b>	
			0 - 255	Colour saturation control - fine (255=default)	proportional
<b>12</b>	<b>10</b>	<b>14</b>		<b>Blue/Yellow (8 bit) *</b>	
			0 - 255	Colour saturation control - coarse 0-100% (255=default)	proportional
<b>13</b>	<b>*</b>	<b>15</b>		<b>Blue/ Yellow (16bit) *</b>	
			0 - 255	Colour saturation control - fine (255=default)	proportional
<b>14</b>	<b>11</b>	<b>16</b>		<b>White (8 bit)</b>	
				<i>If RGBW mode is selected:</i>	
			0-255	Colour saturation control - coarse 0-100% (255=default)	proportional
				<i>If CMY mode is selected:</i>	
			0 - 255	No function	
<b>15</b>	<b>*</b>	<b>17</b>		<b>White (16 bit)</b>	
			0 - 255	Colour saturation control - fine (255=default)	proportional
<b>16</b>	<b>12</b>	<b>18</b>		<b>CTC</b>	
				<i>If function "White Point 8000K" is On:</i>	
			0-255	Col. temperature correction from 8000K to 2700K -for whites only (0=8000K, 64=5600K, 128=4200K, 192=3200K, 255=2700K)	proportional

DMX protocol

Mode/channel			DMX Value	Function	Type of control
1	2	3			
				To get colour temperatures stated above, RGBW channels have to be set at the same value e.g. 255DMX (0=default)	
				<i>If function "White Point 8000K" is Off:</i>	
			0-255	Colour temperature correction for from cool white to 2700K	proportional
<b>17</b>	<b>13</b>	<b>19</b>		<b>Colour Mix control</b>	
				<i>Defines relation between colour channels</i>	
				"Virtual" = Virtual Colours (Virtual Colour Wheel)	
				"Colour mix" = Colour channels (RGBW/CMY)	
			0-9	Virtual colors ("Virtual" has priority)	step
			10-19	Maximum mode (highest values have priority)	step
			20-29	Minimum mode (lowest values have priority)	step
			30-39	Multiply mode (multiply Virtual and Colour Mix)	step
			40-49	Addition mode (Virtual + Colour mix) (45=default)	step
			50-59	Subtraction mode (Virtual – Colour mix)	step
			60-69	Inverted Subtraction mode (Virtual – Colour mix)	step
			70-128	Reserved	
			129	Virtual colors (virtual has priority)	step
			130-254	Crossfade (crossfade between Virtual and Colour mix)	proportional
			255	Colour channels ("Colour mix" has priority)	step
<b>18</b>	<b>14</b>	<b>20</b>		<b>Zoom</b>	
			0-255	Zoom from max. to min.beam angle (128=default)	proportional
<b>19</b>	*	<b>21</b>		<b>Zoom - fine</b>	
			0-255	Fine zooming (0=default)	proportional
<b>20</b>	<b>15</b>	<b>22</b>		<b>Shutter/ strobe</b>	
			0 - 31	Shutter closed	step
			32 - 63	Shutter open (32=default)	step
			64 - 95	Strobe-effect from slow to fast	proportional
			96 - 127	Shutter open	step
			128 - 143	Opening pulse in sequences from slow to fast	proportional
			144 - 159	Closing pulse in sequences from fast to slow	proportional
			160 - 191	Shutter open	step
			192 - 223	Random strobe-effect from slow to fast	proportional
			224 - 255	Shutter open	step
<b>21</b>	<b>16</b>	<b>23</b>		<b>Dimmer intensity (8 bit)</b>	
			0 - 255	Dimmer intensity from 0% to 100% (0=default)	proportional
<b>22</b>	*	<b>24</b>		<b>Dimmer intensity - fine (16 bit)</b>	
			0 - 255	Fine dimming (0=default)	proportional
*Select RGB or CMY mixing mode on channel "Power/Special functions" .					
Copyright © 2020-2022 Robe Lighting s.r.o. - All rights reserved					
All Specifications subject to change without notice					

<b>Robin LEDBeam 350/Robin LEDBeam 350 FW - colours on Virtual Colour Wheel (software version 2.5 /IC3/ and higher)</b>				
<b>Colour name</b>	<b>Red (DMX)</b>	<b>Green (DMX)</b>	<b>Blue (DMX)</b>	<b>White (DMX)</b>
Filter 4 (Medium Bastard Amber)	255	118	0	109
Filter 25 (Sunset Red)	255	47	0	3
Filter 19 (Fire)	255	13	0	0
Filter 26 (Bright Red)	255	0	0	0
Filter 58 (Lavender)	103	0	96	165
Filter 68 (Sky Blue)	30	219	116	17
Filter 36 (Medium Pink)	255	74	8	34
Filter 89 (Moss Green)	69	245	0	3
Filter 88 (Lime Green)	187	226	0	0
Filter 90 (Dark Yellow Green)	7	255	0	0
Filter 49 (Medium Purple)	255	0	27	0
Filter 52 (Light Lavender)	244	88	6	202
Filter 102 (Light Amber)	223	164	0	0
Filter 103 (Straw)	191	144	0	28
Filter 140 (Summer Blue)	0	156	3	242
Filter 124 (Dark Green)	29	255	0	12
Filter 106 (Primary Red)	242	1	1	0
Filter 111 (Dark Pink)	255	67	11	49
Filter 115 (Peacock Blue)	0	255	33	42
Filter 126 (Mauve)	255	0	39	0
Filter 117 (Steel Blue)	180	255	14	253
Filter 118 (Light Blue)	0	218	77	30
Filter 122 (Fern Green)	98	255	0	4
Filter 182 (Light Red)	255	16	2	0
Filter 121 (Filter Green)	165	255	0	0
Filter 128 (Bright Pink)	255	0	13	32
Filter 131 (Marine Blue)	73	219	29	55
Filter 132 (Medium Blue)	0	216	120	0
Filter 134 (Golden Amber)	166	83	0	0
Filter 135 (Deep Golden Amber)	255	50	0	0
Filter 136 (Pale Lavender)	140	95	25	111
Filter 137 (Special Lavender)	112	90	62	196
Filter 138 (Pale Green)	241	255	4	58
Filter 798 (Chrysalis Pink)	64	0	154	51
Filter 141 (Bright Blue)	0	198	62	5
Filter 147 (Apricot)	190	107	0	15
Filter 148 (Bright Rose)	255	3	0	40
Filter 152 (Pale Gold)	193	122	0	46
Filter 154 (Pale Rose)	222	118	0	47
Filter 157 (Pink)	255	56	8	43
Filter 143 (Pale Navy Blue)	0	193	76	143
Filter 162 (Bastard Amber)	211	153	6	36
Filter 164 (Flame Red)	255	27	0	4
Filter 165 (Daylight Blue)	40	236	93	81
Filter 169 (Lilac Tint)	199	123	0	127
Filter 170 (Deep Lavender)	199	129	46	37

<b>Colour name</b>	<b>Red (DMX)</b>	<b>Green (DMX)</b>	<b>Blue (DMX)</b>	<b>White (DMX)</b>
Filter 172 (Lagoon Blue)	0	255	74	7
Filter 194 (Surprise Pink)	91	0	21	204
Filter 180 (Dark Lavender)	136	43	181	120
Filter 181 (Congo Blue)	19	0	255	9
Filter 197 (Alice Blue)	79	193	154	36
Filter 201 (Full C.T. Blue)	153	223	66	156
Filter 202 (Half C.T. Blue)	216	217	34	135
Filter 203 (Quarter C.T. Blue)	248	230	24	120
Filter 204 (Full C.T. Orange)	235	131	4	3
Filter 219 (Fluorescent Green)	99	148	16	50
Filter 206 (Quarter C.T. Orange)	199	152	0	60
Filter 247 (Filter Minus Green)	255	79	0	187
Filter 248 (Half Minus Green)	255	138	0	112
Filter 281 (Three Quarter C.T. Blue)	225	255	99	189
Filter 285 (Three Quarter C.T. Orange)	181	121	0	15
Filter 352 (Glacier Blue)	3	168	62	90
Filter 353 (Lighter Blue)	5	187	34	154
Filter 507 (Madge)	255	31	0	0
Filter 778 (Millennium Gold)	255	65	0	0
Filter 793 (Vanity Fair)	255	0	13	16