



HEADLIGHT 2500

P-1448

This product manual contains important information about the safe installation and use of this projector. Please read and follow these instructions carefully and keep this manual in a safe place for future reference.

PR LIGHTING LTD.

Yingbin Road, Dashi Panyu, Guangzhou, 511430 China

<http://www.pr-lighting.com>

INDEX

SECTION	PAGE
SAFE USAGE OF THE PROJECTOR	3
TECHNICAL DATA	4
CONSTRUCTION	4
FITTING THE LAMP	4
POWER SUPPLY – MAINS	5
ADJUSTING HEAD ANGLE	5
REFLECTOR-BOWL OPERATION	5
MAINTENANCE	6
KEEPING THE PROJECTOR CLEAN	6
TROUBLESHOOTING	6
ELECTRICAL DIAGRAM	7

Please note that as part of our ongoing commitment to continuous product development, specifications are subject to change without notice. Whilst every care is taken in the preparation of this manual we reserve the right to change specifications in the course of product improvement. The publishers cannot be held responsible for the accuracy of the information herein, or any consequence arising from them.

Every apparatus has been tested completely and packed properly by the manufacturer. Please make sure the packing and / or the apparatus is in good condition before your installation and use. Should there be any damage caused by transportation, consult your dealer and do not use the apparatus. But any damage caused by improper use will not be assumed by the manufacturer and / or dealer.

ACCESSORIES

THESE ITEMS ARE PACKED TOGETHER WITH THE PROJECTOR

- 3-Pin power socket (1PCS)
- Tool for screw (2PCS)
- This manual (1 PCS)

INTRODUCTION

Thank you for purchasing the product HEADLIGHT 2500, P-1448.

This product manual contains important information about the safe installation and use of this projector. Please read and follow these instructions carefully and keep this manual in a safe place for future reference.

The HEADLIGHT is an innovative projector with an elegant housing made from high quality aluminium-alloy with an epoxy paint finish and it complies to CE norms and standards. The protection against dust and liquid is high, IP 33. The rotative reflector-bowl produces a spray of 31 white beams, and the light beams are bright and sharp which can be visible for up to 10 kilometres, and the various beam colours can be available with the customer's desire. The projector has safety devices both of auto thermal cut off and lamp power cut off. When the temperature exceeds the allowance value, the lamp will be switched off automatically, and the lamp will be switched on automatically when the lamp cools to the allowance temperature value. If you make a mistake operation to replace the lamp such as open the projector-head cover without switching off the power, the lamp and relative fans will be stopped automatically to avoid the light damaging your eyes and relative fans cutting your fingers. As described above, it is an ideal luminaire to light up buildings, exhibitions or for artistic applications.

SAFE USAGE OF THE PROJECTOR

When unpacking and before disposing of the package check there is no transportation damage before using the projector. Should there be any damage caused by transportation, consult your dealer and do not use the apparatus. Keep the package well for your possible future transportation.

The projector is intended for outdoor use and is splash-proofed, IP33. Install only in dry and plain locations. Avoid excessive moisture.

The projector is not designed or intended to be mounted directly on to inflammable surfaces.



The projector is only intended for installation, operation and maintenance by qualified personnel.

The projector must be installed in a location with adequate ventilation, at least 50cm from adjacent surfaces. Be sure that all the cooling fans run normally and no ventilation slots are blocked.

Do not project the beam onto inflammable surfaces, minimum distance is 5m. \sphericalangle 5m E

Avoid direct exposure to the light from the lamp. The light is harmful to the eye.

Do not attempt to dismantle and / or modify the projector in any way.

Electrical connection must only be carried out by qualified personnel.

Before installation, ensure that the voltage and frequency of power supply match the power requirements of the projector. Only use the lamp with the specified type and rating.

It is essential that each projector is correctly earthed and that electrical installation conforms to all relevant standards.

Do not connect this device to any dimmer pack.

Make sure that the power-cord is never crimped or damaged by sharp edges. Never let the power-cord come into contact with other cables. Only handle the power-cord by the plug. Never pull out the plug by tugging the power-cord.

Keep the lamp clean. Do not touch the lamp glass with bare hand.

The lamp used in this projector is an high power discharge lamp. After being switched off don't attempt to restart the projector until lamp has cooled, this will require approx 15 minutes. Switching the lamp on and off at short intervals will reduce the life of both the lamp and the projector. Occasional breaks will prolong the life of both the lamp and the projector.

Never run the projector without a lamp.

During the initial start-up some smoke or smell may arise. This is a normal process and does not necessarily mean that the device is defective.

There are no user serviceable parts inside the projector, do not open the housing and never operate the projector with the covers removed.

Always disconnect from the mains, when the device is not in use or before cleaning it or before attempting any maintenance work.

If you have any questions, don't hesitate to consult your dealer or manufacturer.

TECHNICAL DATA

Power supply:	230V AC 50Hz
Power consumption:	2800W
Lamp:	HMI 2500W, double ends (Rated working life: 500 hours)
Colour temperature:	6000°K
Control operation:	Stand-Alone
Beam effect:	32 rotative beams (Beam colours can be ordered)
Beam coverage:	35 °
Head movement:	Pan 110°, Tilt manually adjustable through 40°
Dimensions:	740mm LONG x 540mm WIDE x 780mm HIGH
Net weight:	61 kg

CONSTRUCTION

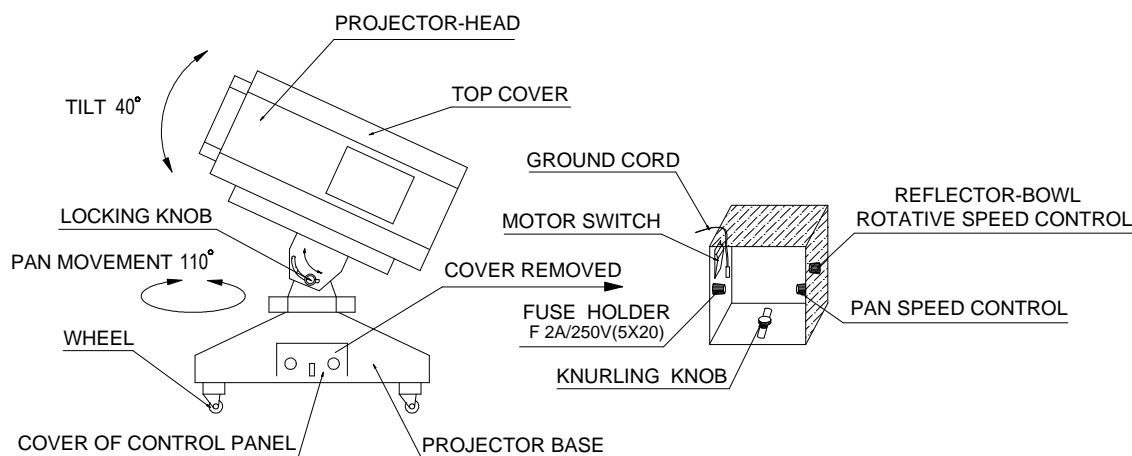

FITTING THE LAMP

Remove the projector-head cover by undoing the 10 M4 screws.

Insert the lamp in the lamp-holder, and ensure the little bubble on the lamp is at a right angle (90°) to the beam path. Keep the lamp clean during installation.

Tighten the 2 M4 lamp fixing screws only manually.

Reinstall the projector-head cover and retighten the 10 M4 screws.

NOTE: The HMI series are high pressure lamps with external igniters (\triangle). Care should always be taken when handling these lamps. Always read the manufacturers "Instructions for use" enclosed with the lamp.

POWER SUPPLY - MAINS

Use the plug provided to connect the mains power to the projector paying attention to the voltage and frequency marked on the panel of the projector. It is recommended that each projector is supplied separately so that they may be individually switched on and off. It is recommended that the projector connect to the mains using a 3-pin 32A plug.

ADJUSTING HEAD ANGLE

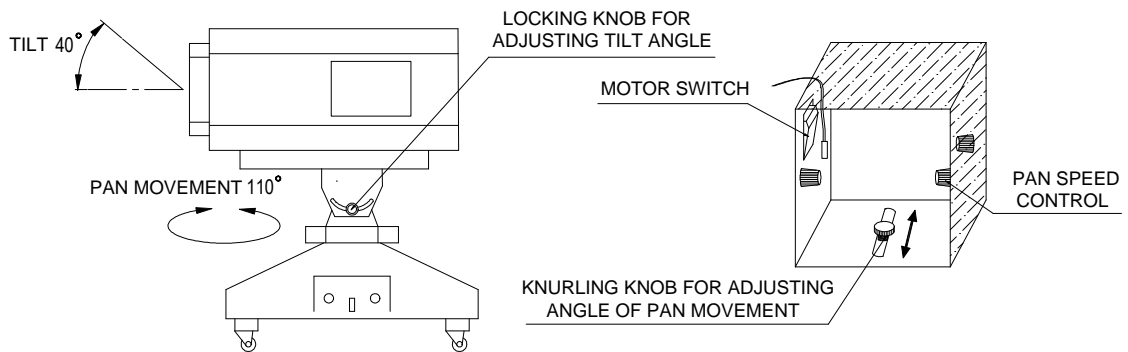

TO ADJUST THE ANGLE OF TILT

You can adjust the angle of tilt from 0° to 40° by loosening the 2 locking knobs. In order to avoid that the head turns over, make sure that you hold the projector-head. After adjusting the desired angle of tilt, tighten the 2 locking knobs sufficiently.

TO ADJUST THE ANGLE OF PAN-MOVEMENT

The projector-head can rotate automatically at an angle of 110 degrees. And it can rotate at any angles within 110 degrees by adjusting the knurling screw. Pressing the motor switch, you can stop the pan movement. Rotating the pan speed control, you can adjust the speed of pan movement.

REFLECTOR-BOWL OPERATION

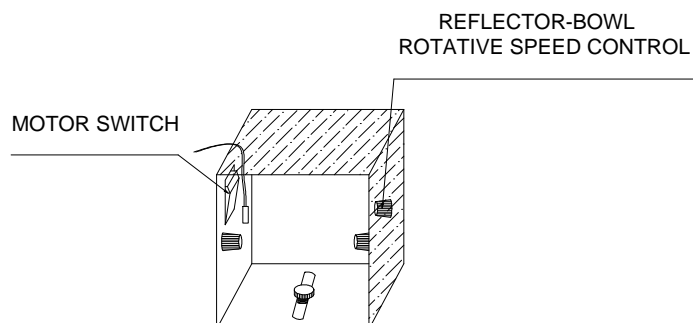

With the **reflector-bowl control**, you can adjust the rotation speed of the reflector-bowl.

Pressing the **motor switch**, you can stop the reflector-bowl rotating.

MAINTENANCE

If the lamp becomes damaged or deformed in any way it must be replaced. If the light from the lamp appears dim this would normally indicate that it is reaching the end of its life and it should be changed at once, old lamps run to the extremity of their life can explode. If the projector does not function, check the fuse in the projector base, it should only be replaced by fuse of the same specified value 20A/380V (fast blow, ceramic). On the main PCB inside the projector there is also a fuse rated 2A/250V (fast blow, 5mmx20mm). Should these be damaged call a qualified technician before replacement. The projector has thermal protection device that will switch off the projector in case of overheating, should this operate, check that the fans are not blocked, and if they are dirty clean them before switching on the projector again. Check that the fans are operational, if not call a qualified technician.

Any maintenance work should only be carried out by a qualified technician.

KEEPING THE PROJECTOR CLEAN

To ensure the reliability of the projector it should be kept clean. It is recommended that the fans should be cleaned every 15 days. The dichroic colour filters should also be regularly cleaned to maintain an optimum light output. **Do NOT use any type of solvent on dichroic colour filters.**

Cleaning frequency depends on the environment in which the fixture operates: damp, smoke or particularly dirty surroundings can cause greater accumulation of dirt on the unit's optics. A soft cloth and typical glass cleaning products should be used in cleaning.

Do not use any organic solvent, e.g. alcohol, to clean the housing of the projector.

TROUBLESHOOTING

PROBLEM	RESOURCE
The projector does not start	Check that the fuse is not blown. Check that the lamp is ok. Check that the head cover is installed correctly.
The projector only functions intermittently	Check the fan is working and not dirty.
The beam appears dim	Check the lamp is not at the end of its life.
Reflector-bowl and head do not rotate	Adjust the relative control inside the control panel Press the motor switch inside the control panel.
Projector with halo	Carefully clean the lamp and optical group lenses.
Defecting projector	Check the lenses are not broken. Remove dust or grease stored on lenses.

ELECTRICAL DIAGRAM

230V ~ 50Hz

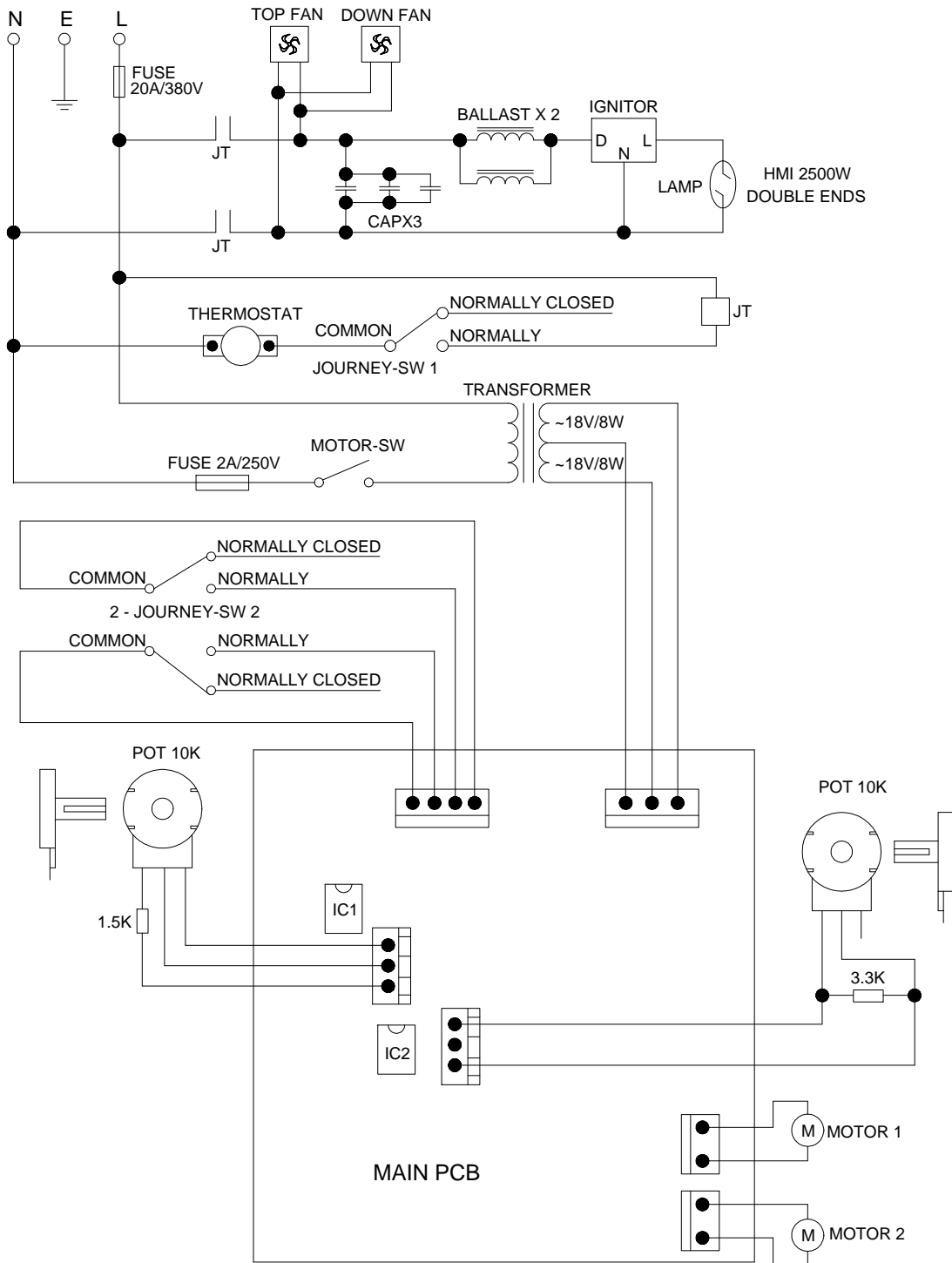

COMPONENT ORDER CODES

NAME	CODE NO.	REMARK
TRANSFORMER	040020011	AC230V/50Hz
IGNITOR	040090004	AC230V/50Hz
BALLAST	040070007	AC230V/50Hz
JT (RELAY)	192010009	AC230V/20A
JOURNEY-SW 1	190010026	
JOURNEY-SW 2	190010030	
THERMOSTAT	190010026	90 /10A
POT (RHEOSTAT)	200010002	
CAP	140010018	60 μ F/AC370V
TOP FAN	030060015	AC230V/0.23A
DOWN FAN	030060013	AC230V/0.14A
LAMP	100050009	HMI 2500W, DOUBLE ENDS
MOTOR 1, 2	030050004	
IC1, IC2	170050006	ARITHMETIC AMPLIFIER CHIP

PR LIGHTING LTD.

Yingbin Road, Dashi, Panyu, Guangzhou, China
Post-Code: 511430
TEL: 020-8478-1888
FAX: 020-8478-6023

P/N: 320040020
Last Revision: 17:12:2002