



LIGHT TECHNOLOGY



Victory II ²⁵⁰

automated luminaire

rel. 1.02

user manual

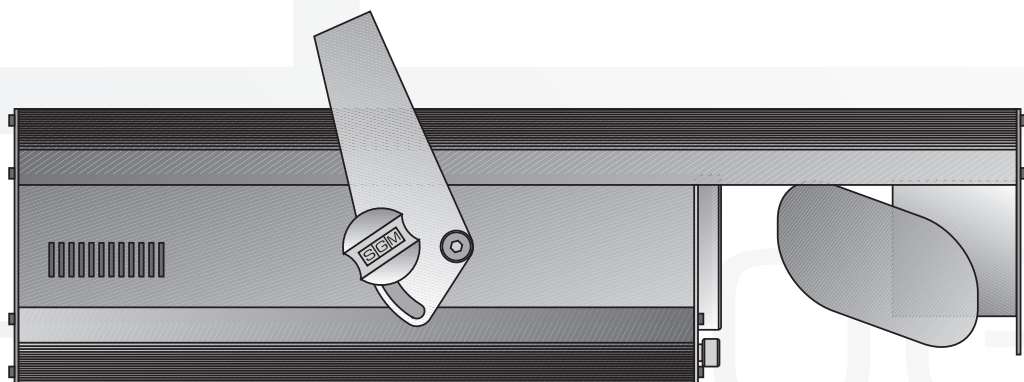

General warnings

Carefully read the warnings contained in this manual, since they supply important instructions concerning safety of installation, use and maintenance.

It is very important that this manual be kept with the equipment for future consultation. In case of sale or transfer of the equipment to another user, ensure that this manual always accompanies the equipment to allow the new owner to obtain information about the operation and the relevant warnings.

- Not for residential use.
- After unpacking check the integrity of the equipment. In case of doubt, do not use the equipment, and contact an authorized SGM Technical Service Centre.
- The packaging materials (plastic bags, expanded polystyrene, nails, etc.) must be kept out of reach of children since they are potential sources of danger.
- This equipment may only be operated by adults. Do not allow children to tamper with the machine or play with the product.
- The electrical work necessary for the installation of the equipment must be carried out by a qualified electrician or by a competent person.
- Before connecting the unit, check that the data on the registration plate is the same as that of the electrical grid.
- Avoid using the equipment:
 - in places subject to excessive humidity
 - in places subject to vibrations or knocks
 - in places with temperatures higher than 45°C or lower than 2°C
 - Protect the equipment from excessively humid conditions (the optimum values are between 35 and 80%).
- Do not disassemble or modify the equipment.
- Prevent inflammable liquids, water or metallic objects from penetrating the equipment.
- In case of spilling liquid on the equipment, immediately disconnect the power supply of the mixer.
- The minimum distance between the projector and the surface to be illuminated must not be less than 1.5 m.
- In case of serious functioning problems, switch off the equipment and contact the nearest SGM retailer or the manufacturer directly for inspection.
- Avoid opening the equipment: there are no parts repairable by the user.
- Never try to repair the equipment alone. Repairs carried out by inexperienced persons may cause damage or serious malfunctioning. Contact the nearest authorised Technical Service Centre.

Always insist on original spare parts.

Protect the environment: do not throw the packaging in your dustbin, but return it to your retailer or take it to a collection point for special waste disposal.



appendice

Index

- 1 General warnings
- 2 Indice
- 3 Main characteristics
 - 3 Lamp
 - 3 Optics
 - 3 Focusing
 - 3 Mirror
 - 3 Strobe
 - 3 Dimmer
 - 4 Iris
 - 4 Shutter
 - 4 Colour and colour conversion filter
 - 4 Luminous beam diffusion
 - 4 Gobo
 - 4 Prism
- 5 Technical characteristics
- 6 Positioning and focusing
 - 6 Positioning
 - 6 Focus adjustment
- 7 Victory II 250 maintenance
 - 7 Access to inside
 - 7 Lamp mounting and replacement
 - 7 Cleaning/ Periodic checks
- 8 Colour replacement
- 8 Gobo replacement
- 8 Start addresses
- 9 Victory connections
- 10 "Options" Dip-switch
 - 10 Pan/Tilt - Normal/Reverse
 - 10 Mirror 8/16-bit res.
 - 10 Auto/Remote mode
- 10 Control channels
 - 11 ch 1 - dimmer
 - 11 ch 2 - colour
 - 12 ch 3 - gobo
 - 13 ch 4 - shutter/strobe
 - 13 ch 7 - gobo rotation
 - 14 ch 8 - palette
 - 14 ch 9 - prism and prism rotation
 - 14 ch 10 - reset



LIGHT TECHNOLOGY

Made in Italy by SGM Electronic

Printed in September, 1998 • Rel. 1.02

Main Characteristics

The intelligent projectors of the Victory series spring from a design philosophy which all SGM products have for years had in common. These new scanners, because of their avant-garde performance, certainly take top place among the best in world-wide production. The accurate study of the functions, the search for innovative materials, the continuous technical updating have led to the realization of a certainly unique product: Victories are projectors suitable for a multitude of applications.

The vast and pluridecennial experience of SGM in the sector of light control systems has allowed developing a product with high reliability and precision, of which the mechanics, optics and electronics are entirely designed by our own research laboratories. This allows absolute mastery of the know-how and optimisation of the quality/price relation.

As every SGM product before commercialisation, the Victories have brilliantly passed the long testing period and the strict tests they have had to undergo - this is synonymous with high quality and reliability.

The particular care over the aesthetics, and the optimisation of the outer structure aimed at functionality, allow easy installation in any position and extremely fast technical intervention.

The Victories are constructed in conformity with the CE regulations currently in force.

Lamp

The Victories use an extra low-voltage incandescent halogen lamp with a 2-pin connector, without doubt the ideal lamp for this type of projector, since it combines good reliability with long life (about 300 hours). It has surprising luminous power at ridiculously low cost, absolutely incomparable with other metallic iodide lamps mounted on projectors of the same type.

Optic system

The special SGM-designed parabola able to concentrate the luminous beam, and the condenser lens in selected glass with a high transmission coefficient, subjected to special multilayer antireflection treatment, exalt the brilliance and luminous power of the Victories whose brightness is positively astounding.

Focusing

Focusing the Victories is extremely easy, fast and with absolute precision from the screw panel located on the front of the projector (Focus). Focusing is accurate on all the gobos as they are all arranged on the same wheel.

Mirror

The mobile mirror of the Victories has ultra-high reflection able to reduce the loss of luminous yield to a minimum. The scanning time is 0.5 seconds for the 90(Pan and 0.3 seconds for the 180(Tilt. Extremely elaborate software and the use of first-class motors have allowed obtaining a movement capability which is ultrafast, precise and very linear even at lower speeds. Moreover, the Victories accept 16-bit control which ensures a linearity of movement unbeatable among the projectors in this range. Mirror scanning can also be inverted to facilitate installation and programming.

Strobe

The stroboscopic effect of the Victories is extremely fast for a projector of this category and may be adjusted by the operator to a frequency from 1 to 9 flashes a second.

Dimmer

The Victories are also fitted with a dimmer function so that the light intensity may be dimmed from 0 to 100%.

Diaphragm

The Victorys do not have a mechanical iris, but the 8-position gobo wheel has a position to shape the luminous beam, thus obtaining a narrower beam which, for example, can be directed at a mirrored globe, or used to satisfy any other special need. Since the gobo is interchangeable, the amplitude of the luminous beam may be selected from the many available.

Shutter

A shutter is available on the Victorys, which may be activated instantaneously to block the luminous beam output.

Colour and colour conversion filter

On Victory II the 8 base colours are multiplied by a colour-temperature conversion filter, thus obtaining 16 colours. The top-quality 38 (dichroic) filters are carefully selected to guarantee perfect colour uniformity. They are all easily interchangeable, so that also personal requirements can be satisfied.

The colours may be selected as follows:

- fixed positions, full colour
- intermediate positions for two-colour beams
- variable-speed rotation to obtain a spectacular rainbow effect
- passage from one colour to another with or without blackout.
- synchronization of the colour change with the music on fixed positions (Music Hard).

The passage between the different colours is imperceptible to the human eye as it is extremely fast (the absolute fastest among the projectors in this range) and occurs in 0.08 sec.

Diffused light beams

Victory II is equipped with a frost filter to allow emission of diffused light beams to create coloured backgrounds and settings with fixed or variable colours. The frost filter may be combined with the whole range of colours available.

Gobos

The Victory gobo unit consists of a single wheel with 7 images and one empty position. All the gobos are easily interchangeable so that the operator may install new figures easily and quickly.

The gobo change occurs in fast imperceptible mode, or in analog mode with a slow passage from one figure to the next. Selecting the rotagobo function (running of figure adjustable to 4 preset speeds) a special visual effect is obtained.

Victory II is fitted with 4 variable-speed rotating gobos adjustable in the two directions. Gobo change with or without blackout.

The linearity and gobo rotation speed, thanks to an exclusive system created by SGM engineers, is unequalled, and selectable in direction and speed according to the requirements of the operator.

Prism

Victory II is able to create truly innovative and interesting graphic and decorative effects, thanks to the use of a rotating prism lens. The prism rotation speed is adjustable.

The fixed and rotating gobos and the rotating prism are totally independent: this gives the lighting designer a remarkable number of effects to work with, since by merely changing a parameter (direction or rotation speed of the gobo or the prism), the visual effect is changed considerably.

Technical Characteristics

Power supply:	90÷260V - 50/60Hz - Universal, automatic voltage change.
Lamp:	250W 24V-EVC M/33, G6.35 connector - Life approx. 300 hours.
Absorbed power:	300 W
Optic unit:	Mirrored parabola with very high luminous yield, designed for Victory.
Optic system:	Mirrored parabola + 70mmø lens + 90mmø lens, screw focusing.
Lenses:	In glass with high transmission coefficient.
Mirror:	Ultra-high reflection, in special glass.
Electronics:	Entirely developed by engineers of the SGM Research & Development Laboratory. Has a power supply card (CS 0207) and a logic card (CS 0208).
Settings:	By means of dip-switches, to address the control channels of the projector and to set the selectable options: - PAN/TILT scanning inversion; - 8 or 16-bit mirror movement resolution; - Control mode: Remote (from remote control), or Auto for automatic functioning independent of the projector.
Motors:	5 a micro-stepper motors, 5 DC motors.
Input:	Digital serial signal DMX512 or RS232/423.
Control channels:	ch1 - dimmer / ch2 - colour / ch3 - gobos / ch4 - shutter/strobe / ch5 - pan ch6 - tilt / ch7 - gobo rotation / ch8 - palette / ch9 - prism and prism rotation ch10 - reset / ch11 - pan 16bit / ch 12 - tilt 16bit
Mirror movement:	Mirror rotation by means of 2 extra high-precision micro-stepper motors and controlled by the relevant control card. Option to invert mirror scanning.
Safety regulations:	The Victorys are in conformity with current CE regulations.
Safety devices:	IP20 degree of protection. Automatic power cut-off in case of overheating or cooling system operation failure.
Cooling system:	Forced through 1 axial fan.
Body:	In die-cast extruded aluminium. Epoxy-powder enamelling.
Mounting bracket:	In epoxy-powder enamelled steel. Installation position with adjustable inclination over 110°.
Dimensions:	cm 18 x 65 x 35. Weight: Kg 14.

SGM Elettronica reserves the right to make improvements and modifications to its products at any time.
Always refer the manual to the equipment it pertains to in order to avoid mistakes and straying from the actual functions as illustrated in the manual.

Positioning and Focusing

Positioning

To position the projector, the channels must be set as follows:

Channel 1	dimmer	100% open
Channel 2	colour	white
Channel 3	gobos	no figure
Channel 4	shutter/strobe	open
Channel 5/6	pan/tilt	centre position
Channel 7	gobo rotation	off
Channel 8	palette	none
Channel 9	prism	off

Position the projector rotating it on its support bracket, then lock it in the desired position with the knobs.

Focus adjustment

To adjust the lens, the channels must be set as follows:

Channel 1	dimmer	100% open
Channel 2	colour	white
Channel 3	gobos	position on a figure
Channel 4	shutter/strobe	open
Channel 5/6	pan/tilt	in position on the point where focus is desired
Channel 7	gobo rotation	off
Channel 8	palette	none
Channel 9	prism	off

Focusing the Victories is very easy, fast and with absolute precision through the screw knob located on the front of the projector (Focus). Focusing is accurate on all the gobos as they are all arranged on the same wheel.

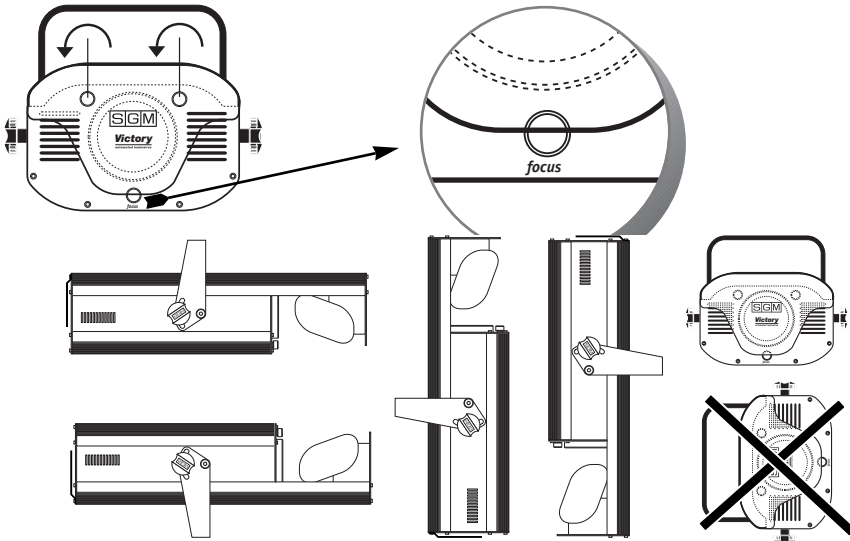

Victory II 250 Maintenance

Access to inside

Victory has a particular way of access to the inside of the projector. Remaining fixed as installed, the projector can be opened exactly halfway in longitudinal direction, thus allowing easy access to the inner parts in order to carry out any necessary operation, be it cleaning, lamp change or service of any mechanical or electrical part.

To open the projector, unscrew the 2 knobs on the front (Fig. 1), taking care that the lower part does not drop downwards suddenly when the screws are undone. A locking lever (Fig. 3) will automatically hold it open at maximum travel.

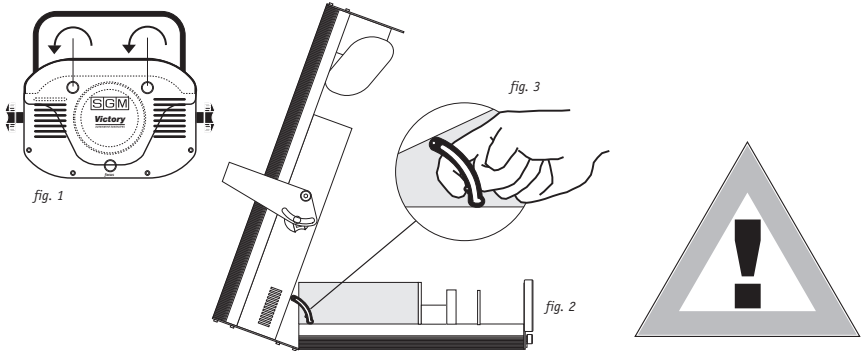

Lamp mounting or replacement

WARNING: Before replacing the lamp:

- Evaluate the effective necessity to replace the lamp (average lamp life about 300 h).
- Disconnect the projector from the mains.
- If the projector was on, before opening it, wait for the lamp and the internal mechanical parts to cool down (10÷30 minutes)

Remove the burnt-out lamp. Be extremely careful not to touch the optics, the parabola and the lamp with bare hands, since the residuals subjected to high temperatures burn, causing the parts to blacken and irreparably damaging the lamp. Proceed with mounting the new lamp placing it carefully in its housing.

FOR GOOD PROJECTION IT IS VERY IMPORTANT THAT THE LAMP FITS PERFECTLY IN THE SOCKET.

After each lamp replacement it is recommended to carry out a complete cleaning cycle.

After carrying out the necessary operations, before pushing the lower part towards the top (Fig. 2) to close the projector, release the locking lever lifting it towards the top (Fig. 3). Screw down the 2 knobs one after the other, taking care that these have properly hooked the lower part to prevent it from suddenly dropping downwards.

Projector cleaning / Periodic checks

Cleaning the optics - internally and externally - is determining for maximum luminous yield and should periodically be carried out. The cleaning frequency above all depends on the place where the projector operates. In particular, a humid environment with a great deal of smoke or dust favours greater accumulation of dirt on the projector optics. Clean with a soft cloth using normal window-cleaning products or denatured alcohol, always carefully drying the parts. Clean the external optics at least every 15-20 days and the internal optical unit (condenser lenses, parabola) and gobo unit

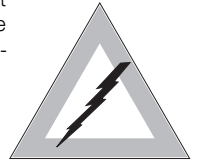

(including the rotation system) at least every 40-60 days. To ensure an always perfectly efficient projector, a general overall inspection every 700 hours of operation is recommended. Checking of the electrical and mechanical parts must be carried out by technical staff.

Colour replacement

Open the projector after disconnecting it from the mains. If it was on, wait for the lamp and the internal mechanical parts to cool down (about 30 minutes). The colour wheel consists of two parts between which the seats of the colour filters are located.

To replace them: with the finger very gently separate the two locking discs at the point of the dichroic filter to be replaced. Remove the filter and insert the new one. Properly close the wheel and the projector.

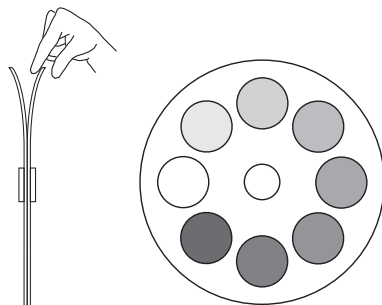

Gobo replacement

Open the projector after disconnecting it from the mains. If it was on, wait for the lamp and the internal mechanical parts to cool down (about 30 minutes). With the aid of a small screwdriver, remove the spring (C), replace the gobo (B), reinsert the spring, taking care to insert it perfectly on the special gobo ring (A). Properly close the projector.

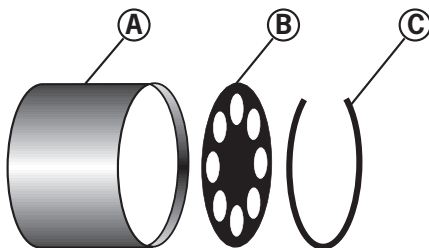

Start Addresses

For connection in DMX512 mode, each projector must appropriately be configured. The start address is set with the dip-switch located on the back of the projector. The address can be modified also when the projector is on.

	1	2	4	8	16	32	64	128	256
Victory II PR0150 #1 (ch 01 ÷ 12)									
Victory II PR0150 #2 (ch 13 ÷ 25)			on	on					
Victory II PR0150 #3 (ch 26 ÷ 38)	on			on	on				
Victory II PR0150 #4 (ch 39 ÷ 51)		on	on			on			

Warning! Always refer to the numbers silk-screen printed on the Victory panel and not to those on the dip-switch.

Victory Connections

The projector is fitted with a DMX512 and RS-232/423 input/output.

When making the start address settings, consider that 4 channels are used (channel 1 is not operational in this version).

For connection in a DMX network always use balanced microphonic cables type RF 60/12 2x0.25mm² or similar and select a good quality to prevent malfunctioning of the projector.

To reduce interference it may be necessary to insert a network terminator on the last projector in the DMX chain, realized with a 120Ω 1/4W resistor placed between pins 2 and 3 of the DMX connector.

Warning: The screening part of the cable (braid) must NEVER be connected to the system earth, since this would lead to malfunctioning of the projector and the control units.

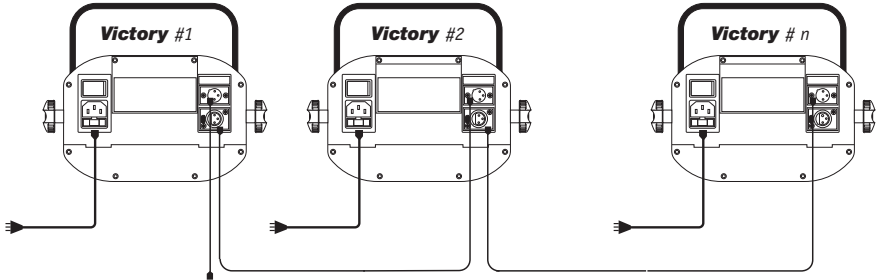

DMX512 or RS-232 line

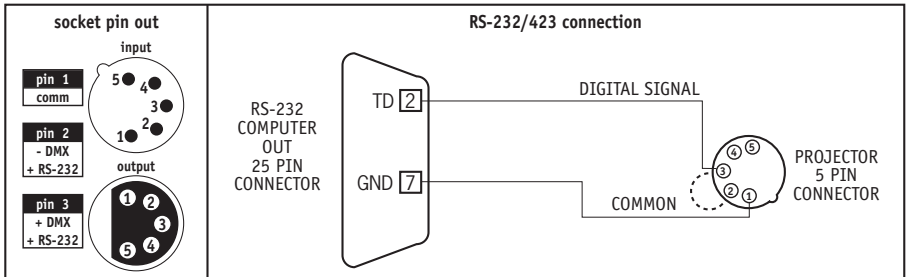

"OPTIONS" Dip-switches

PAN /TILT Normal - Reverse

The PAN and TILT dip-switches are used to invert vertical and horizontal scanning from top to bottom, from left to right and vice versa.

Ex. In the case where two Victorys are installed one in front of the other, moving the joystick to the left/right or top/bottom, the Victorys will have opposite movements. Therefore, to make mirror scanning uniform, act on PAN MOVE/TILT MOVE of one of these.

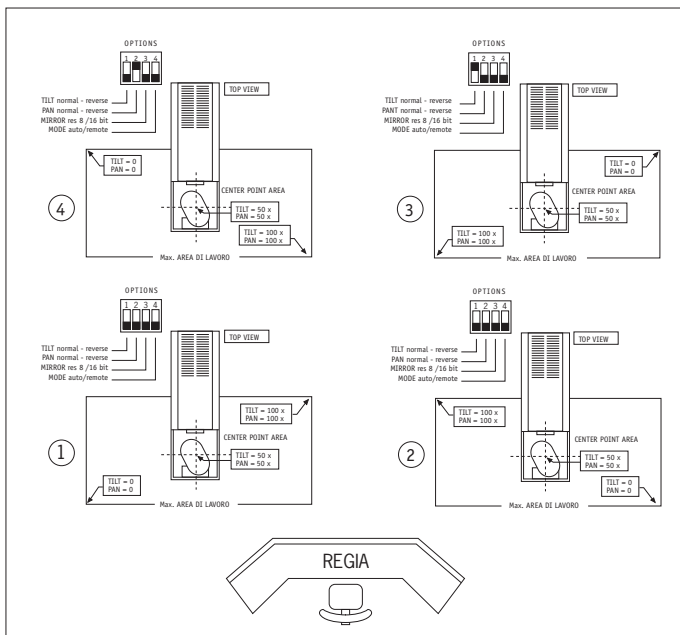
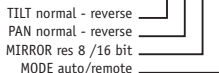
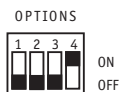

Mirror res 8/16 bit

The Victorys may also be 16-bit controlled on PAN/TILT. This function, which normally is coupled to more professional projectors, guarantees absolute linearity of movement.

To activate this function the OPTIONS dip-switch 3 must be set to ON.

In order to use the 16-bit control, the Victorys need 2 additional control channels, therefore passing from 10 to 12 channels.

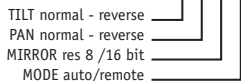

Auto/remote mode

The Victorys can also function autonomously without the control auxiliary. To activate this function the OPTIONS dip-switch 4 must be set to OFF. The projector will start running 8 resident programs (AUTO) in a continuous cycle.

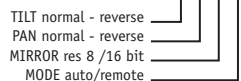

Control channels

ch 1

dimmer

Adjustable from channel 1, allows linear adjustment of the light intensity from 0 to 100% according to operator requirements.

ch 2

colour

On Victory II the 8 base colours are multiplied by a colour-temperature conversion filter, thus obtaining 16 colours. The top-quality 38 (dichroic filters are carefully selected to guarantee perfect colour uniformity. They are all easily interchangeable, so that also personal requirements can be satisfied.

The colours may be selected as follows:

- fixed positions, full colour
- intermediate positions for two-colour beams
- variable-speed rotation to obtain a spectacular rainbow effect
- passage from one colour to another with or without blackout.
- synchronization of the colour change with the music on fixed positions (Music Hard).

The passage between the different colours is imperceptible to the human eye as it is extremely fast (the absolute fastest among the projectors in this range) and occurs in 0.08 sec.

To activate change with blackout, channel 4 (shutter) must be set to a value of between 199 and 211.

<i>Value</i>	<i>Color</i>
0÷9	White
10÷19	White + Yellow
20÷29	Yellow
30÷39	Yellow + Magenta
40÷49	Magenta
50÷59	Magenta + Cyan
60÷69	Cyan
70÷79	Cyan + Orange
80÷89	Orange
90÷99	Orange + Green
100÷109	Green
110÷119	Green + Blue
120÷129	Blue
130÷139	Blue + Red
140÷149	Red
150÷159	Red + White
160÷170	Rainbow - speed 1
171÷180	Rainbow - speed 2
181÷191	Rainbow - speed 3
192÷201	Rainbow - speed 4
202÷212	Rainbow - speed 5
213÷223	Rainbow - speed 6
224÷233	Rainbow - speed 7
234÷244	Rainbow - speed 8
245÷255	Music hard change

ch 3

gobo

The gobo wheel is adjustable from Channel 3.

All the gobos are easily interchangeable, the light filter diameter is 34 mm. The gobo selection is controlled by optical sensors located near the wheel. The Victory gobo unit consists of only one wheel with 7 images and one empty position. All the gobos are easily interchangeable so that the operator may install new figures easily and quickly.

The gobo change occurs in fast imperceptible mode, or in analog mode with a slow passage from one figure to the next. Selecting the rotagobo function, (running of figure adjustable to 4 preset speeds) allows obtaining a special visual effect.

Other than 3 fixed gobos, Victory II is fitted with 4 variable-speed rotating gobos adjustable in the two directions. Gobo change with or without blackout.

The linearity and gobo rotation speed, thanks to an exclusive system created by SGM engineers, is unequalled, and selectable in direction and speed.

Channel 3 interacts with channel 4. From channel 4 the operator may select gobo change with blackout (values 186(198), or slow gobo change (values 225(237)).

<i>Value</i>	<i>Gobo</i>
0÷19	No gobo
20÷39	Gobo 1 rotante
40÷59	Gobo 2
60÷79	Gobo 3 rotante
80÷99	Gobo 4
100÷119	Gobo 5 rotante
120÷139	Gobo 6
140÷159	Gobo 7 rotante
160÷177	Rotagobo - speed 1
178÷194	Rotagobo - speed 2
195÷212	Rotagobo - speed 3
213÷229	Rotagobo - speed 4
230÷255	Music Hard change gobo

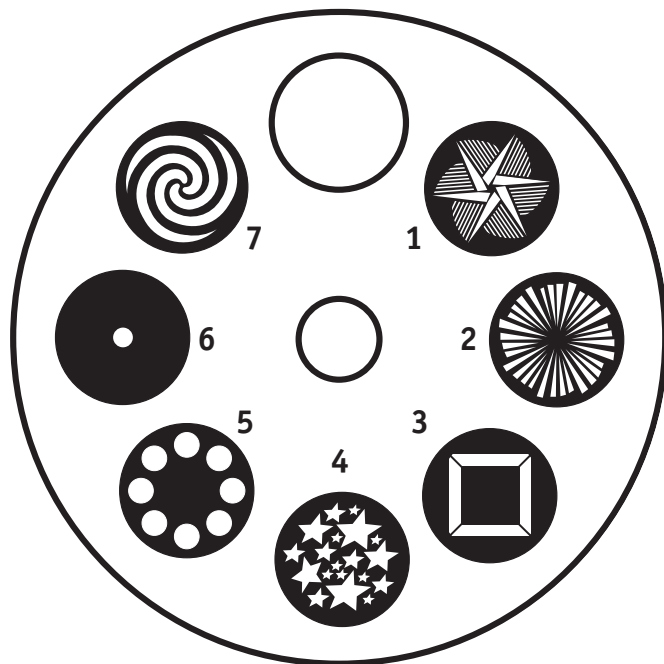

ch 4

shutter/strobe

The shutter/strobe is adjustable from Channel 4.

Use of iMusic Flash! is recommended (see table), which gives a remarkable visual impact.

Channel 4 interacts with channel 2 and channel 3 (values 186(237).

It can enable colour change and/or gobo change with blackout, as well as analog gobo change (slow).

Value	Shutter/Strobe
0÷9	Shutter closed
10÷19	Strobe - 1 fps
20÷29	Strobe - 1.39 fps
30÷39	Strobe - 1.65 fps
40÷49	Strobe - 1.94 fps
50÷59	Strobe - 2.34 fps
60÷69	Strobe - 2.78 fps
70÷79	Strobe - 3.29 fps
80÷89	Strobe - 3.91 fps
90÷99	Strobe - 4.56 fps
100÷109	Strobe - 5.45 fps
110÷119	Strobe - 5.98 fps
120÷129	Strobe - 6.98 fps
130÷139	Strobe - 7.85 fps
140÷149	Strobe - 9 fps
150÷159	Shutter Sync: audio low freq
160÷172	Flash Sync: audio low freq
173÷185	Flash Sync: audio high freq
186÷198	Shutter open & auto shade gobos
199÷211	Shutter open & auto shade colours
212÷224	Shutter open & auto shade gobos+colours
225÷237	Shutter open, low speed gobo change
238÷255	Shutter open

ch 7

gobo rotation

Channel 7 controls variable-speed rotation in the two directions of the rotating gobos (pos. 1,3,5,7).

Value	Rotating gobos
0÷112	cw rotation speed regulation
113÷142	stop rotation
143÷255	ccw rotation speed regulation

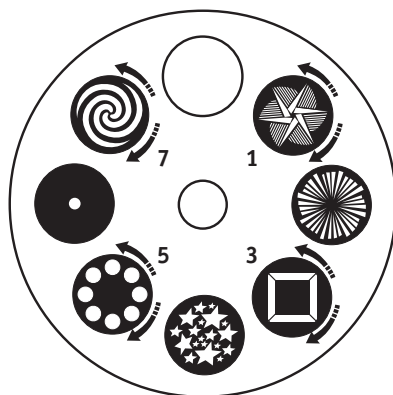

ch 8

palette

Channel 8 controls activation of the palettes which activate the colour conversion and frost filter.

The colour conversion filter allows doubling the number of colours projected by Victory II: from the 8 base colours 16 are thus obtained.

The frost filter allows generating diffused light, ideal to create coloured backgrounds.

<i>Value</i>	<i>Palette</i>
0÷63	Off
64÷127	Colour conversion filter
128÷191	Frost
192÷255	Colour cov. filter + frost

ch 9

prism and prism rotation

Victory II is able to create truly innovative and interesting graphic and decorative effects, thanks to the use of a rotating prism lens. The prism rotation speed is adjustable.

The fixed and rotating gobos and the rotating prism are totally independent: this gives the lighting designer a remarkable number of effects to work with, since by merely changing a parameter (direction or rotation speed of the gobo or the prism), the visual effect is changed considerably.

<i>Value</i>	<i>Prism</i>
0÷49	Off
50÷79	Prism on - not rotating
80÷255	Prism rotating speed (min to max)

ch 10

reset

Whenever necessary, perhaps due to an imperfect electric line, reset the Victory logic (which may feel the effects of interference on the network when very powerful) from the controller driving the projector. This may be done thanks to the remote reset, first of all activating it on the logic circuit (CS0208) from the relevant dip-switch. Then it can be used according to the following table:

<i>Value</i>	<i>Reset</i>
0÷49	Off
50÷234	Lamp hysteresis
235÷255	Reset

cod. M001095



LIGHT TECHNOLOGY

Via Pio La Torre, 1 • 61010 TAVULLIA (PS) • ITALY •

Tel. +39 0721476477 • Fax +39 0721476170

www.sgm.it • info@sgm.it